

# MAGMA FOG 1500 IP-II

## SPECIFICATIONS / TECHNICAL DATA

### KEY FEATURES

- 1500W IP67 water-based fogger
- 60,000 CFM (cu ft/min) maximum output
- 40 second burst @ 100% output
- Continuous burst @ 20% output
- Thermally protected heat exchanger
- Intuitive DMX-512 and RDM control
- Onboard LCD touch screen
- Optional wireless and wired remotes

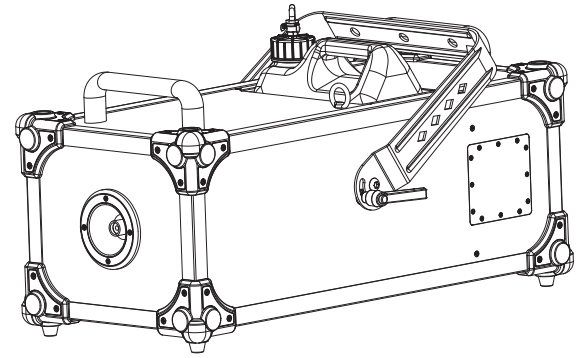

### PRODUCT DESCRIPTION

The **MAGMA FOG 1500 IP-II™** is a 1500W water based, IP67 rated fog machine with a maximum output of 60,000 CFM (cu ft/min). Features include an easy-to-use onboard LCD touch screen, an intuitive DMX-512 and RDM control, and optional wired and wireless remote-control. Each **MAGMA FOG 1500 IP-II** comes equipped with a thermally protected heat exchanger that has an initial warm up time of 14 minutes, with a fluid consumption rate of 6.76 oz (200 ml/min). This unit is designed with a durable aluminum housing, IP67 locking power in, IP67 locking 5pin XLR connectors (DMX In/Out), a 5-liter (1.32 gallon) tank, two heavy duty carry handles, and a hanging bracket for truss mounting.

### PRODUCT SPECIFICATIONS

#### PERFORMANCE

- Rated Power: 1500W
  - Max Output: 60,000 CFM\* (cu ft/min.)
  - Ready Time: Initial = 14 Minutes\*
  - Fluid Capacity: 1.32 gallons (5 liters)
  - Fluid Consumption: 6.76 oz/min (200 ml/min)
- \*approximate

#### COMPATIBLE FLUID

- Atmosity Extreme Filtered Fog Fluid (AEF-2L, AEF-4L, AEF-20L)
- Atmosity Quick Fog Fluid (AFF-2L, AFF-4L, AFF-20L)

#### CONSTRUCTION

- Thermally Protected Heat Exchanger
- Rugged Case Design
- Convenient Carry Handles

#### CONTROL

- 3 DMX Channel Modes (1 / 2 / 4)
- Onboard LCD Touch Control Panel
- DMX-512 and RDM Protocol Support
- Optional MAGFLY Wireless DMX Transceiver
- Optional MAGRF Wireless and MAGREMOTE Wired Remotes



# MAGMA FOG 1500 IP-II

## SPECIFICATIONS / TECHNICAL DATA

### CONNECTIONS

Locking 5pin XLR Connector, DMX In/Out  
IP67 Locking Power Connector In  
With Wired Digital Communication Network  
Locking 4pin XLR Connector for Manual Remote

### SIZE / WEIGHT

Length: 25.5 in. (648mm)  
Width: 13.3 in. (337mm)  
Height: 16.2 in. (411mm)  
Weight: 74.3 lbs. (33.7kg)

### ELECTRICAL

AC120V 60Hz (US Version)  
AC230V 50Hz (EU Version)  
20A @ 120VAC(NFB)  
10A @ 230VAC - 240VAC  
Max Power Consumption: 1600W

### THERMAL

Maximum Ambient Temperature (Ta max) 104°F (40°C)  
Exterior Surface Temperature, Steady State: 149°F (65°C)

### ACCESSORIES

MagFLY (MSR934) Wireless DMX Transceiver Module  
MagRF (MSR912) RF Module and Wireless Remote

### APPROVALS / RATINGS

CE | IP67

Specifications and documentation subject to change without notice.

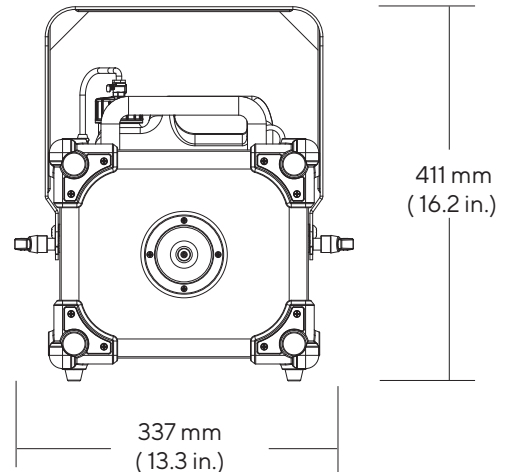
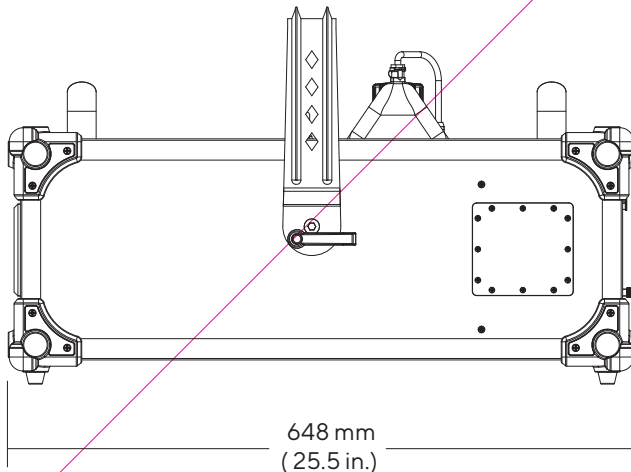

MAGMATIC