



PROTEUS BRUTUS

user manual

©2022 ELATION PROFESSIONAL all rights reserved. Information, specifications, diagrams, images, and instructions herein are subject to change without notice. ELATION PROFESSIONAL logo and identifying product names and numbers herein are trademarks of ELATION PROFESSIONAL. Copyright protection claimed includes all forms and matters of copyrightable materials and information now allowed by statutory or judicial law or hereinafter granted. Product names used in this document may be trademarks or registered trademarks of their respective companies and are hereby acknowledged. All non-ELATION brands and product names are trademarks or registered trademarks of their respective companies.

ELATION PROFESSIONAL and all affiliated companies hereby disclaim any and all liabilities for property, equipment, building, and electrical damages, injuries to any persons, and direct or indirect economic loss associated with the use or reliance of any information contained within this document, and/or as a result of the improper, unsafe, insufficient and negligent assembly, installation, rigging, and operation of this product.

Elation Professional USA | 6122 S. Eastern Ave. | Los Angeles, CA. 90040

323-582-3322 | 323-832-9142 fax | www.elationlighting.com | info@elationlighting.com

Elation Professional B.V. | Junostraat 2 | 6468 EW Kerkrade, The Netherlands

+31 45 546 85 66 | +31 45 546 85 96 fax | www.elationlighting.eu | info@elationlighting.eu

Elation Professional Mexico | AV Santa Ana 30 | Parque Industrial Lerma, Lerma, Mexico 52000

+52 (728) 282-7070

DOCUMENT VERSION



Due to additional product features and/or enhancements, an updated version of this document may be available online. Please scan the QR Code with your mobile device or visit www.elationlighting.com for the latest revision/update of this manual, before installation and/or programming.

| Date | Document Version | SoftwareVersion ≥ | DMX Channel Modes | Notes |
|---------|------------------|-------------------|-------------------|-----------------|
| 8/01/22 | 1 | 1.0.0 | 25, 36, 34, 56 | Initial Release |
| | | | | |
| | | | | |
| | | | | |
| | | | | |
| | | | | |
| | | | | |
| | | | | |

CONTENTS

| | |
|---|-----------|
| General Information | 4 |
| Limited Warranty (USA Only) | 5 |
| Safety Guidelines | 6 |
| Maintenance Guidelines | 9 |
| Overview | 10 |
| Colors and Gobos | 11 |
| Gobo Installation | 13 |
| Iris & Framing Assembly Installation | 14 |
| Torque Settings for Screws | 15 |
| Fan Modes and Low Noise Operation | 16 |
| Installation Guidelines | 17 |
| Sun Protection Mode Hibernation Mode | 22 |
| System Menu | 23 |
| Dimmer Curve | 30 |
| DMX Traits: Channel Functions & Values | 31 |
| Remote Device Management (RDM) | 39 |
| Error Codes | 40 |
| Elation Ethernet Updater | 41 |
| Specifications | 45 |
| Dimensional Drawings | 46 |
| Optional Accessories | 48 |

GENERAL INFORMATION

FOR PROFESSIONAL USE ONLY

INTRODUCTION

Please read and understand the instructions in this manual carefully and thoroughly before attempting to operate this device. These instructions contain important safety and use information.

IP65 RATED

An IP rated lighting fixture is one, which is commonly installed in outdoor environments and has been designed with an enclosure that effectively protects the ingress (entry) of external foreign objects such as dust and water. **The International Protection (IP)** rating system is commonly expressed as **"IP"** (Ingress Protection) followed by two numbers (i.e. IP65) where the numbers define the degree of protection. The first digit (Foreign Bodies Protection) indicates the extent of protection against particles entering the fixture and the second digit (Water Protection) indicates the extent of protection against water entering the fixture. An **IP65** rated lighting fixture is one, which has been designed and tested to protect against the ingress of dust **(6)** and low-pressure water jets from any direction **(5)**.

COOLING

After usage, the lamp may be switched off, but the fixture should remain connected to power in order to allow the fan time to cool down the fixture.

UNPACKING

Every device has been thoroughly tested and has been shipped in perfect operating condition. Carefully check the shipping carton for damage that may have occurred during shipping. If the carton is damaged, carefully inspect the device for damage, and be sure all accessories necessary to install and operate the device have arrived intact. In the event damage has been found or parts are missing, please contact our customer support team for further instructions. Please do not return this device to your dealer without first contacting customer support. Please do not discard the shipping carton in the trash. Please recycle whenever possible.

BOX CONTENTS

Omega Brackets (x2)

IP65 Rated 5pin DMX Cable

IP65 Rated RJ45 DATA Cable (Fixture to Fixture Interconnect Use Only!)

IP65 Rated Power Cable

CUSTOMER SUPPORT

Contact ELATION Service for any product related service and support needs.

Also visit forums.elationlighting.com with questions, comments or suggestions.

ELATION SERVICE USA - Monday - Friday 8:00am to 4:30pm PST

323-582-3322 | Fax 323-832-9142 | support@elationlighting.com

ELATION SERVICE EUROPE - Monday - Friday 08:30 to 17:00 CET

+31 45 546 85 63 | Fax +31 45 546 85 96 | support@elationlighting.eu

REPLACEMENT PARTS please visit parts.elationlighting.com

LIMITED WARRANTY (USA ONLY)

- A. Elation Professional hereby warrants, to the original purchaser, Elation Professional products to be free of manufacturing defects in material and workmanship for a period of two years (730 days), and Elation Professional product rechargeable batteries to be free of manufacturing defects in material and workmanship for a period of six months (180 days), from the original date of purchase. This warranty excludes discharge lamps and all product accessories. This warranty shall be valid only if the product is purchased within the United States of America, including possessions and territories. It is the owner's responsibility to establish the date and place of purchase by acceptable evidence, at the time service is sought.
- B. For warranty service, send the product only to the Elation Professional factory. All shipping charges must be pre-paid. If the requested repairs or service (including parts replacement) are within the terms of this warranty, Elation Professional will pay return shipping charges only to a designated point within the United States. If any product is sent, it must be shipped in its original package and packaging material. No accessories should be shipped with the product. If any accessories are shipped with the product, Elation Professional shall have no liability what so ever for loss and/or damage to any such accessories, nor for the safe return thereof.
- C. This warranty is void if the product serial number and/or labels are altered or removed; if the product is modified in any manner which Elation Professional concludes, after inspection, affects the reliability of the product; if the product has been repaired or serviced by anyone other than the Elation Professional factory unless prior written authorization was issued to purchaser by Elation Professional; if the product is damaged because not properly maintained as set forth in the product instructions, guidelines and/or user manual.
- D. This is not a service contract, and this warranty does not include any maintenance, cleaning or periodic check-up. During the periods as specified above, Elation Professional will replace defective parts at its expense, and will absorb all expenses for warranty service and repair labor by reason of defects in material or workmanship. The sole responsibility of Elation Professional under this warranty shall be limited to the repair of the product, or replacement thereof, including parts, at the sole discretion of Elation Professional. All products covered by this warranty were manufactured after January 1, 1990, and bare identifying marks to that effect.
- E. Elation Professional reserves the right to make changes in design and/or performance improvements upon its products without any obligation to include these changes in any products theretofore manufactured.
- F. No warranty, whether expressed or implied, is given or made with respect to any accessory supplied with the products described above. Except to the extent prohibited by applicable law, all implied warranties made by Elation Professional in connection with this product, including warranties of merchantability or fitness, are limited in duration to the warranty periods set forth above. And no warranties, whether expressed or implied, including warranties of merchantability or fitness, shall apply to this product after said periods have expired. The consumer's and/or dealer's sole remedy shall be such repair or replacement as is expressly provided above; and under no circumstances shall Elation Professional be liable for any loss and/or damage, direct and/or consequential, arising out of the use of, and/or the inability to use, this product.
- G. This warranty is the only written warranty applicable to Elation Professional products and supersedes all prior warranties and written descriptions of warranty terms and conditions heretofore published.

WARRANTY RETURNS

All returned service items whether under warranty or not, must be freight pre-paid and accompany a return authorization (R.A.) number. The R.A. number must be clearly written on the outside of the return package. A brief description of the problem as well as the R.A. number must also be written down on a piece of paper and included in the shipping container. If the unit is under warranty, you must provide a copy of your proof of purchase invoice. Items returned without a R.A. number clearly marked on the outside of the package will be refused and returned at customer's expense. You may obtain a R.A. number by contacting customer support.

SAFETY GUIDELINES

This fixture is a sophisticated piece of electronic equipment. To guarantee a smooth operation, it is important to follow all instructions and guidelines in this manual. Elation Professional is not responsible for injury and/or damages resulting from the misuse of this fixture due to the disregard of the information printed in this manual. Only qualified and/or certified personnel should perform installation of this fixture and only the original rigging parts (omega brackets) included with this fixture should be used for installation. Any modifications to the fixture and/or the included mounting hardware will void the original manufacturer's warranty and increase the risk of damage and/or personal injury.



PROTECTION CLASS 1 - FIXTURE MUST BE PROPERLY GROUNDED.



**THERE ARE NO USER SERVICEABLE PARTS INSIDE THIS UNIT.
DO NOT ATTEMPT ANY REPAIRS YOURSELF; DOING SO WILL VOID YOUR MANUFACTURER'S WARRANTY. DAMAGES RESULTING FROM MODIFICATIONS TO THIS FIXTURE AND/OR THE DISREGARD OF SAFETY INSTRUCTIONS AND GUIDELINES IN THIS MANUAL VOID THE MANUFACTURER'S WARRANTY AND ARE NOT SUBJECT TO ANY WARRANTY CLAIMS AND/OR REPAIRS.**



ENSURE ALL CONNECTIONS AND END CAPS ARE PROPERLY SEALED WITH A DIELECTRIC GREASE (AVAILABLE AT MOST ELECTRICAL SUPPLIERS) TO PREVENT WATER CORROSION AND/OR ELECTRICAL SHORT CIRCUIT.



**DO NOT PLUG FIXTURE INTO A DIMMER PACK!
NEVER OPEN THIS FIXTURE WHILE IN USE!
UNPLUG POWER BEFORE SERVICING FIXTURE!
NEVER TOUCH FIXTURE DURING OPERATION, AS IT MAY BE HOT!
KEEP FLAMMABLE MATERIALS AWAY FROM FIXTURE!**

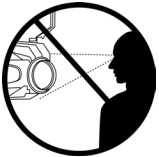

**NEVER LOOK DIRECTLY INTO THE LIGHT SOURCE!
RETINA INJURY RISK - MAY INDUCE BLINDNESS!
SENSITIVE PERSONS MAY SUFFER AN EPILEPTIC SHOCK!**



**MINIMUM DISTANCE TO OBJECTS/SURFACES
MUST BE 65.6 FEET (20 METERS)
MAXIMUM TEMP OF EXTERNAL SURFACE 185° F (85°C)
MINIMUM DISTANCE OF INFLAMMABLE MATERIALS
FROM THE SURFACE 1.6 FEET (0.5 METER)**

SAFETY GUIDELINES

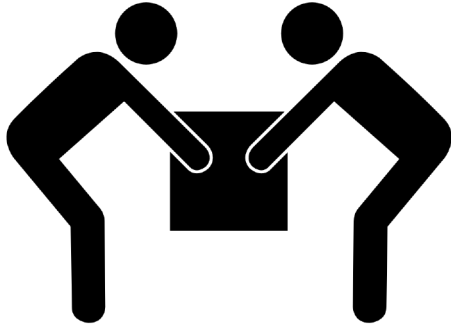

105 lbs. (47.6 kg)

WARNING

TWO PERSON LIFT REQUIRED

! CAUTION

HIGH INTENSITY ULTRAVIOLET LIGHT

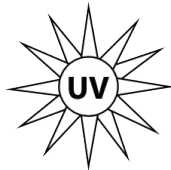

AVOID DIRECT EYE & SKIN EXPOSURE.
WEAR PROPER EYE & SKIN PROTECTION.
SEE MANUAL FOR SAFETY INSTRUCTIONS.

RISK GROUP 3 - RISK OF EXPOSURE TO ULTRAVIOLET UV RADIATION! FIXTURE EMITS HIGH INTENSITY WAVELENGTH OF ULTRAVIOLET UV LIGHT FROM THE UV COLOR FILTER. WEAR PROPER EYE AND SKIN PROTECTION. AVOID PROLONGED PERIODS OF EXPOSURE TO UV COLOR FILTER. AVOID WEARING WHITE COLOR CLOTHING AND/OR USING UV PAINTS ON SKIN. AVOID DIRECT EYE AND/OR SKIN EXPOSURE AT DISTANCES LESS THAN 65.6 feet (20m). DO NOT OPERATE FIXTURE WITH DAMAGED/MISSING EXTERNAL COVERS. DO NOT LOOK DIRECTLY INTO THE UV LIGHT AND/OR VIEW UV LIGHT DIRECTLY WITH OPTICAL INSTRUMENTS THAT MAY CONCENTRATE THE LIGHT/RADIATION OUTPUT. INDIVIDUALS SUFFERING FROM A RANGE OF EYE CONDITIONS, SUNLIGHT

EXPOSURE DISORDERS, OR INDIVIDUALS USING PHOTSENSITIVE MEDICATION, MAY RECEIVE DISCOMFORT IF EXPOSED TO THE ULTRAVIOLET UV LIGHT EMITTED FROM THE UV LED.

DO NOT TOUCH the fixture housing during operation. Turn OFF the power and allow approximately 15 minutes for the fixture to cool down before serving.

DO NOT shake fixture, avoid brute force when installing and/or operating fixture.

DO NOT operate fixture if the power cord is frayed, crimped, damaged and/or if any of the power cord connectors are damaged and do not insert into the fixture securely with ease. NEVER force a power cord connector into the fixture. If the power cord or any of its connectors are damaged, replace it immediately with a new one of similar power rating.

DO NOT block any air ventilation slots.

All fan and air inlets must remain clean and never blocked.

Allow approx. 6" (15cm) between fixture and other devices or a wall for proper cooling.

Always disconnect fixture from main power source before performing any type of service and/or cleaning procedure. Only handle the power cord by the plug end, never pull out the plug by tugging the wire portion of the cord.

During the initial operation of this fixture, a light smoke or smell may emit from the interior of the fixture. This is a normal process and is caused by excess paint in the interior of the casing burning off from the heat associated with the lamp and will decrease gradually over time.

Consistent operational breaks will ensure fixture will function properly for many years.

ONLY use the original packaging and materials to transport the fixture in for service.

SAFETY GUIDELINES

POTENTIAL INTERNAL DAMAGE FROM 'TIPPING' FIXTURE DURING TRANSPORT AND HANDLING

This is a large format fixture that contains delicate optics and glass filters. While this product was carefully designed to be roadworthy, it must be handled carefully during transportation. Before transport, ensure that the color flags inside the unit are placed in an OPEN position.

For superior impact protection, the fixture is shipped in a custom fitted high-density Foam Inlay (FIL). This FIL must be used inside the road-cases for transportation.

DO NOT TIP THE CASE OVER, AND AVOID ALL SHOCKS AND ROUGH HANDLING, ESPECIALLY "TIPPING", THE PRACTICE OF TIPPING THE FIXTURE-CASE OVER TO ITS SIDE AND ONTO A HARD SURFACE. THE CASE MUST RIDE ON ITS WHEELS SO THAT THE FIXTURE-HEAD REMAINS HORIZONTAL DURING TRANSPORTATION.

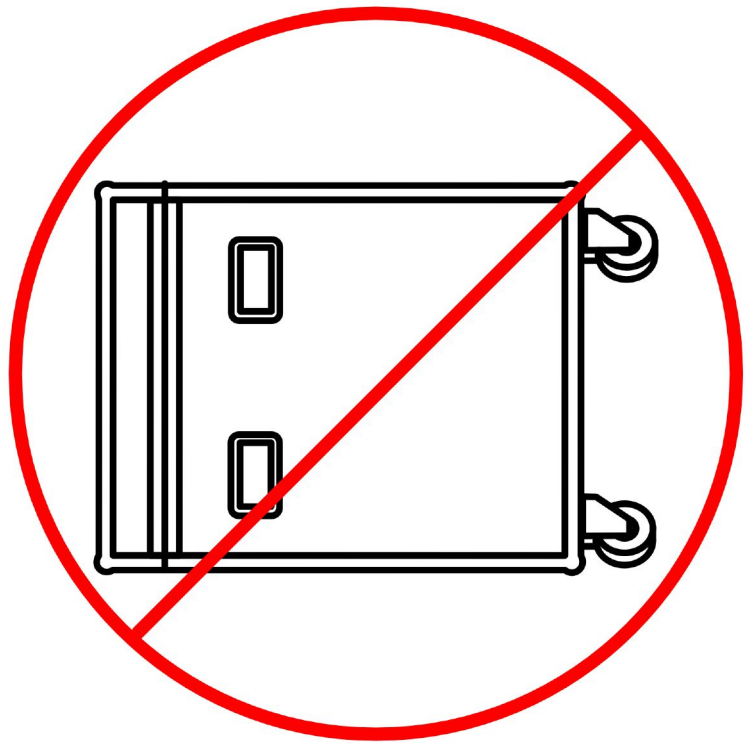
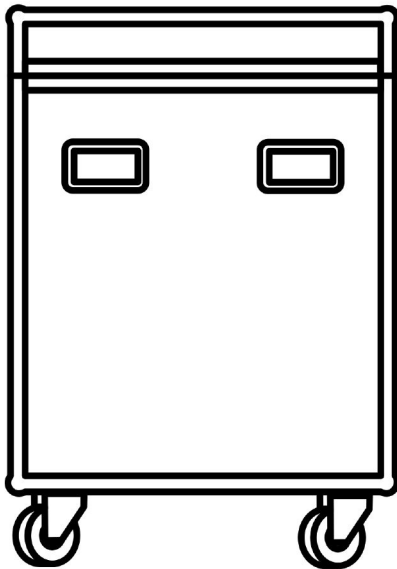

MAINTENANCE GUIDELINES



DISCONNECT POWER BEFORE PERFORMING ANY MAINTENANCE!

CLEANING

Frequent cleaning is recommended to insure proper function, optimized light output, and an extended life. The frequency of cleaning depends on the environment in which the fixture operates: damp, smoky or particularly dirty environments can cause greater accumulation of dirt on the fixture's optics. Clean the external lens surface at least every 20 days with a soft cloth to avoid dirt/debris accumulation.

NEVER use alcohol, solvents, or ammonia-based cleaners.

MAINTENANCE

Regular inspections are recommended to insure proper function and extended life.

There are no user serviceable parts inside this fixture, please refer all other service issues to an authorized Elation service technician. Should you need any spare parts, please order genuine parts from an authorized Elation dealer.

Please refer to the following points during routine inspections:

A detailed electric check by an approved electrical engineer every three months, to make sure the circuit contacts are in good condition and prevent overheating.

Be sure all screws and fasteners are securely tightened at all times. Loose screws may fall out during normal operation resulting in damage or injury as larger parts could fall.

Check for any deformations on the housing, color lenses, rigging hardware and rigging points (ceiling, suspension, trussing). Deformations in the housing could allow for dust to enter into the fixture. Damaged rigging points or unsecured rigging could cause the fixture to fall and seriously injure a person(s).

Electric power supply cables must not show any damage, material fatigue or sediments.

NEVER remove the ground prong from the power cable.

FIXTURE DISASSEMBLY

The following points should be observed after performing any maintenance procedure that requires disassembly of the unit:

- After the unit has been reassembled, open the valve, and allow the light to run for approximately 2 hours in order to dry out any moisture that has been trapped inside the fixture. The process should continue until indicated humidity drops below 15% for the head and 30% for the base.
- Once this has been achieved, the light can be switched off, but the unit should remain connected to power so that the cooling fan can cool down the unit. Please note that allowing cool down time should **ALWAYS** be done after lamp operation.
- Some units may require partial disassembly in order to gain access to the valve. Please contact Elation service for information regarding the location and access procedure for the valve on your specific unit model.

OVERVIEW

MODE/ESC Button Up Button Right Button Enter Button

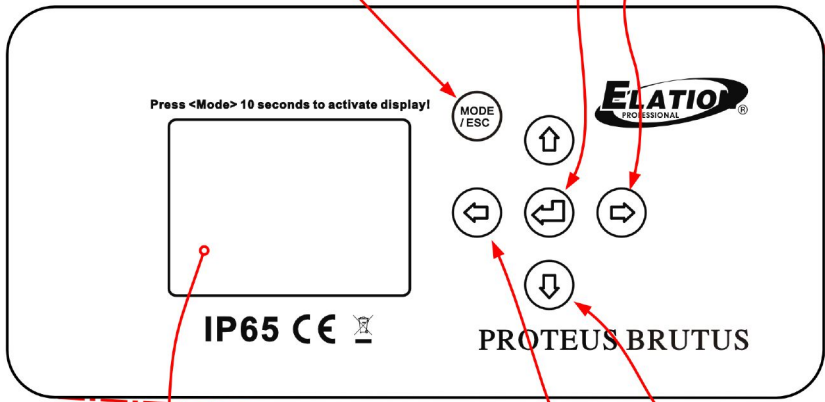

LCD Menu Function Display

Down Button Left Button

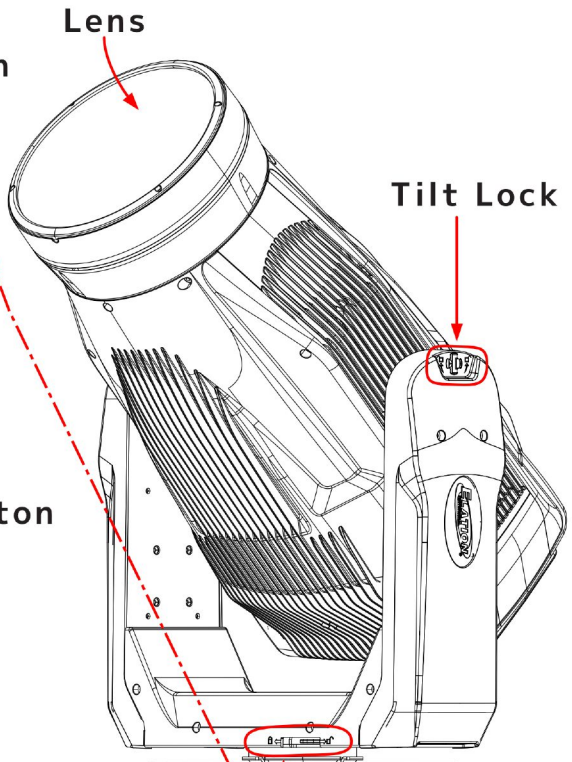
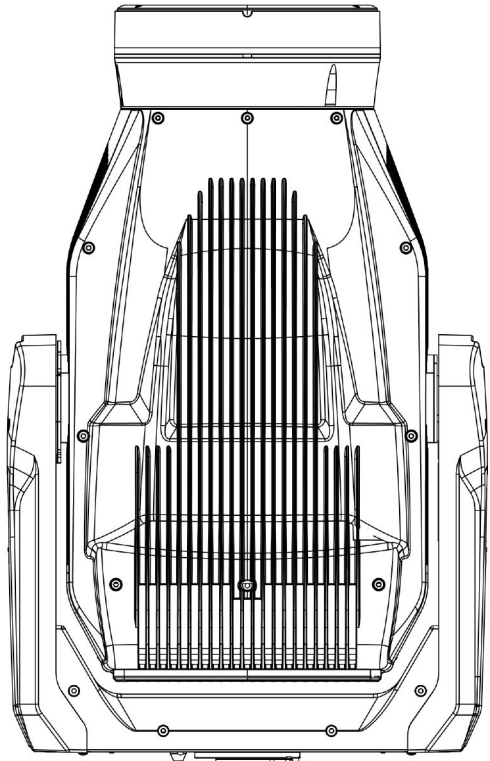

Pan Lock Carrying Handle(s)

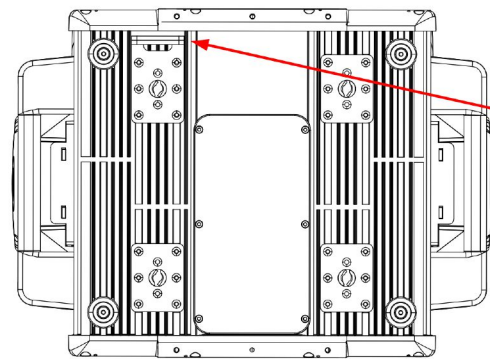
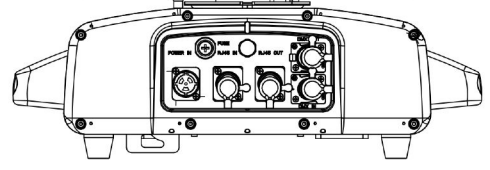

Fuse: T20/250V Locking Power Input Valve 5pin DMX Output

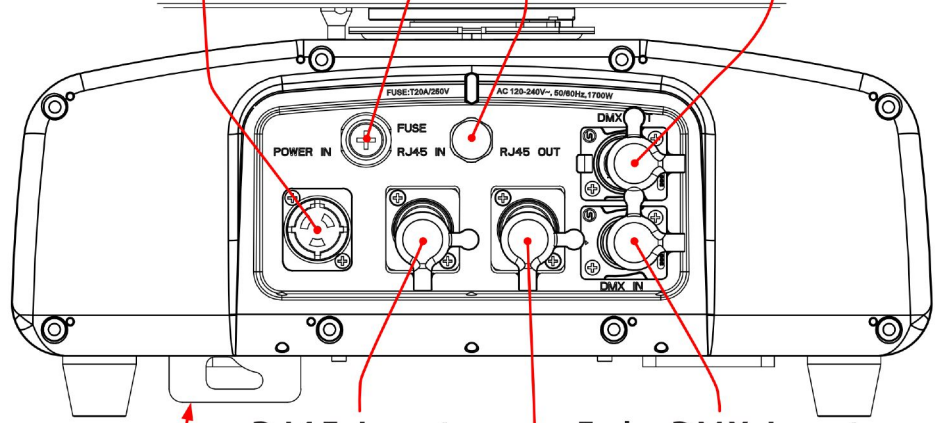

RJ45 Input 5pin DMX Input RJ45 Output

Safety Cable Attachment Point



ALWAYS ATTACH A SAFETY CABLE WHENEVER INSTALLING THIS DEVICE IN A SUSPENDED ENVIRONMENT TO ENSURE THE FIXTURE WILL NOT DROP IF THE CLAMP FAILS.

COLORS AND GOBOS

COLOR FLAGS

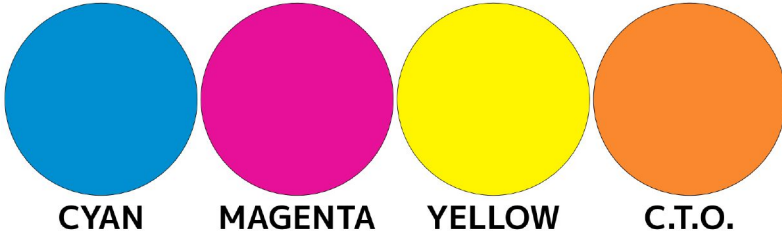

COLOR WHEEL

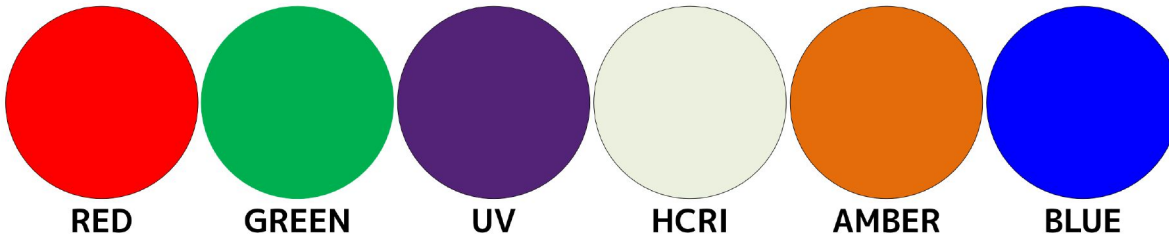

ROTATING GOBO WHEEL1

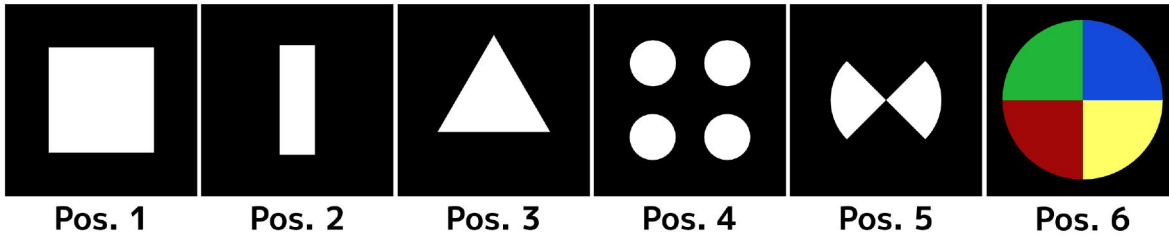

BI-DIRECTIONAL ANIMATION WHEEL

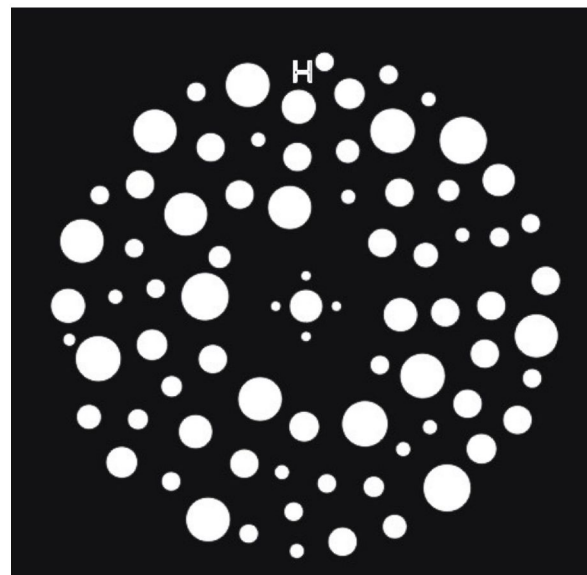

COLORS AND GOBOS

| ROTATING WHEEL GOBOS - Pos. 1-5 | |
|---------------------------------|-------|
| Gobo O.D. (Max. Outer Diameter) | ø34mm |
| Gobo O.D. (Max. Outer Diameter) | ø24mm |
| Gobo Thickness | 1.1mm |
| Gobo Material | METAL |

| ROTATING WHEEL GOBOS - Pos. 6 | |
|---------------------------------|-------|
| Gobo O.D. (Max. Outer Diameter) | ø34mm |
| Gobo O.D. (Max. Outer Diameter) | ø34mm |
| Gobo Thickness | 2.2mm |
| Gobo Material | GLASS |

Rotating Wheel Gobos: Pos. 1-5, & Pos. 6dc

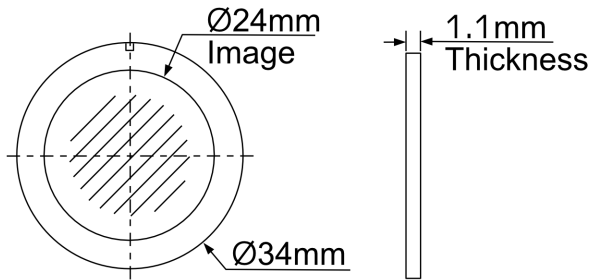

Pos. 1 to Pos. 5

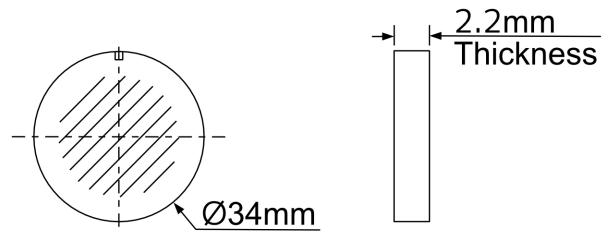

Pos. 6

Rotating Wheel Gobos

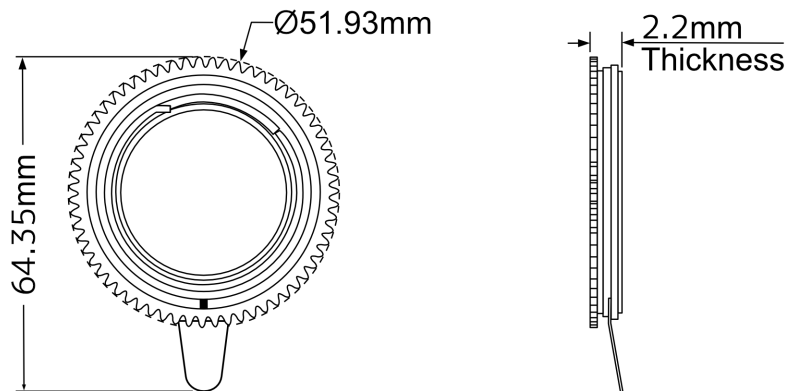

GOBO INSTALLATION

REPLACING A ROTATING GOBO

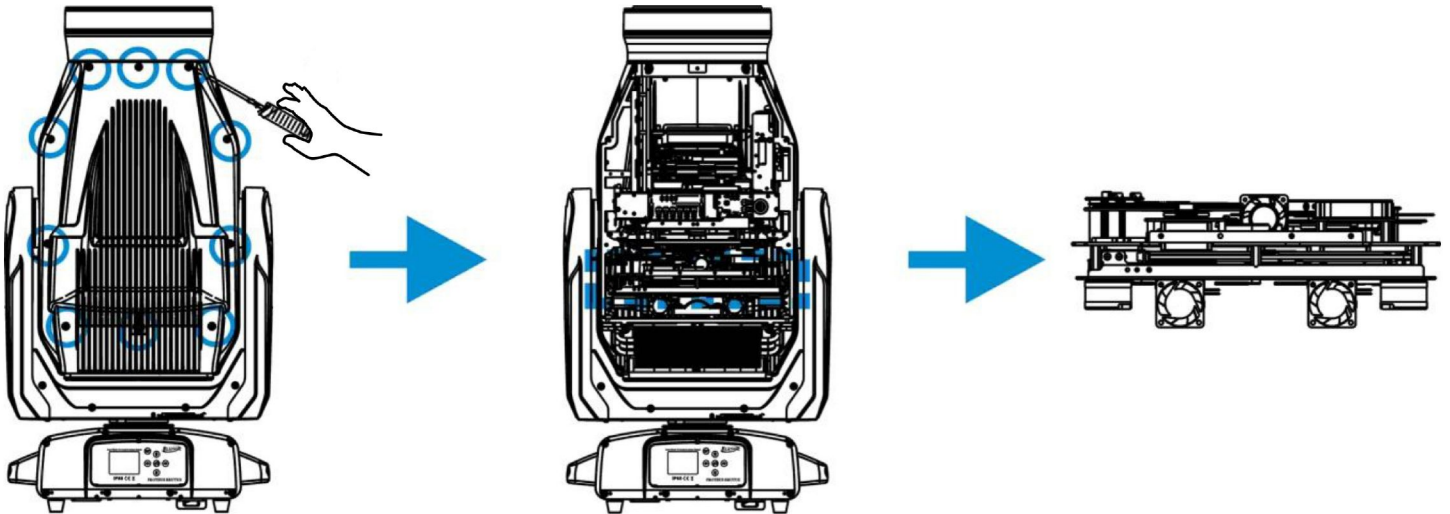

Place the Elation Proteus Brutus fixture on a firm flat surface. Locate the (10x) screws on the side of the moving head and remove them. With the panel set aside, locate the Pattern Bracket Assembly and remove the (4x) screws that secure it to the internal housing frame.

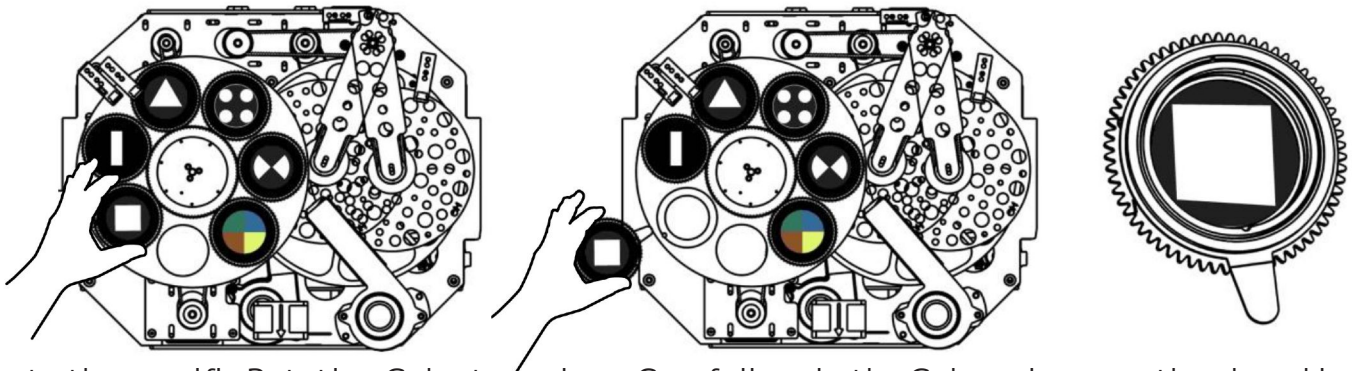

Locate the specific Rotating Gobo to replace. Carefully grip the Gobo using your thumb and index finger, gently lift it slightly, and then pull it out and away until it fully clears the Gobo Wheel.

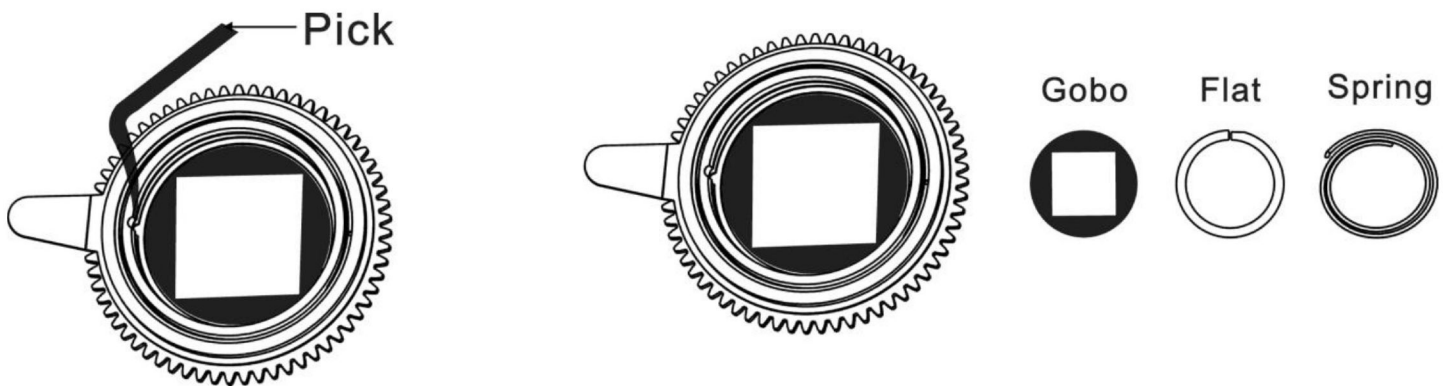

Locate the tab of the spring, and with a precision pick (or similar tool), carefully press the retaining spring inward to relieve the tension. Remove the retaining spring and carefully separate the GOBO from the GOBO Holder. Lastly, remove the flat washer attached to the removed GOBO and attach it to the desired replacement GOBO. Install the replacement Rotating GOBO following the steps above in reverse order.

CAUTION: TAKE CARE NOT TO SCRATCH GOBO OR GOBO HOLDER

IRIS & FRAMING ASSEMBLY INSTALLATION

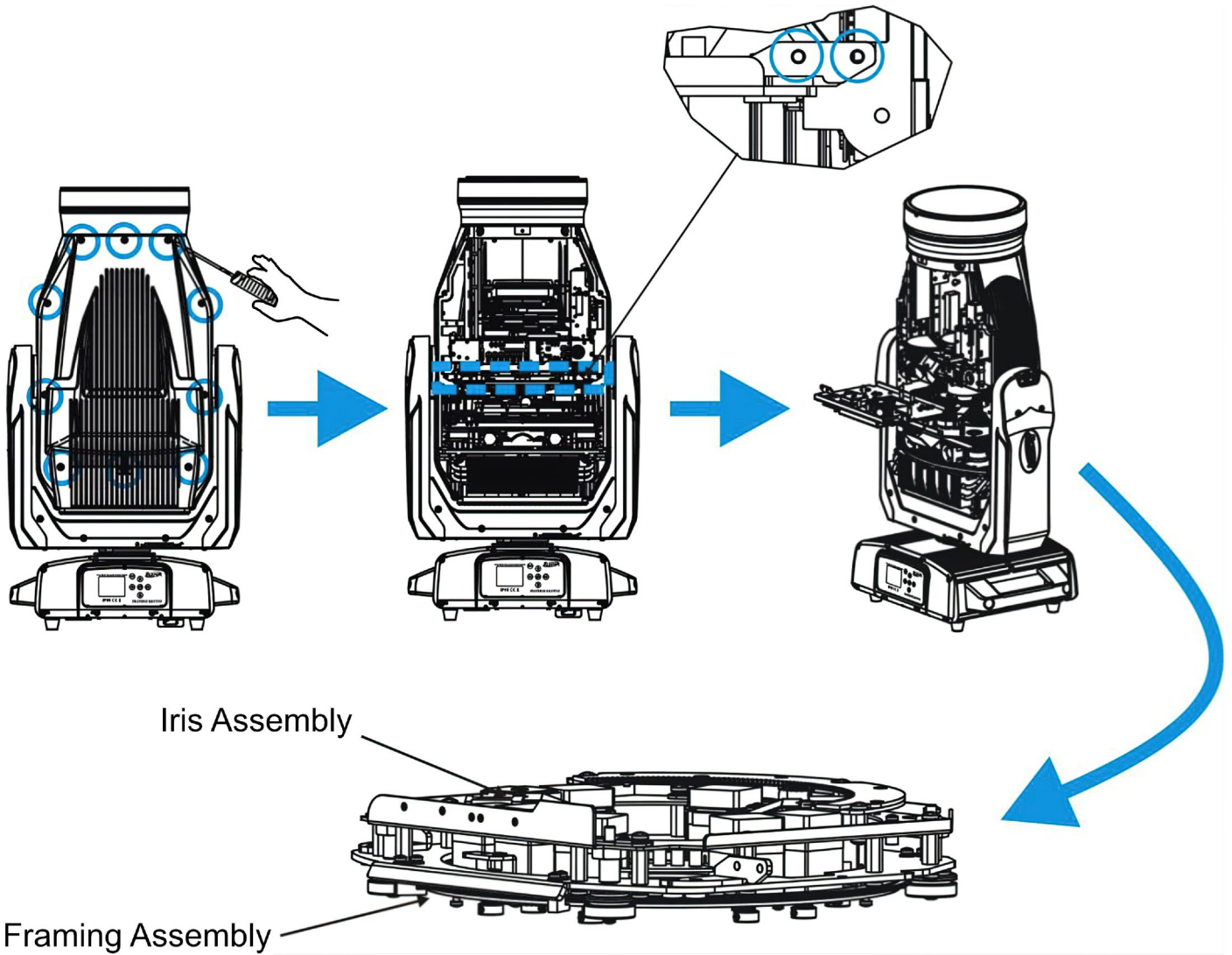

Place the Elation Proteus Brutus fixture on a firm flat surface. Locate the (10x) screws on the side of the moving head and remove them. With the panel set aside, locate the Iris and framing Assembly and remove the (4x) screws that secure it to the internal housing frame. Disconnect all connectors, then carefully remove the Iris and Framing Assembly.

TORQUE SETTINGS FOR SCREWS

The hex-head screws holding either the panels or the base **MUST** be tightened with a torque wrench (not included).

TORQUE SETTINGS:
lbf-in = Pound Force Inches
kgf-cm = Kilogram Force Centimeter:



CAUTION! DO NOT OVER TORQUE SCREWS AS THIS CAN CAUSE LEAKAGE ISSUES!
TO CONFIRM THE IP65 INTEGRITY AFTER A LAMP REPLACEMENT, TEST FIXTURE USING THE ELATION IP TESTER. CONTACT ELATION SERVICE FOR MORE DETAILS.



CAUTION! THE USE OF PROTECTIVE GLOVES AND SAFETY GOGGLES IS STRONGLY RECOMMENDED WHILE PERFORMING THE IP PRESSURE TEST! AVOID PLACING YOUR FACE, EYES, HANDS, ETC IN CLOSE PROXIMITY TO THE FIXTURE'S LENS WHILE PERFORMING THE TEST!

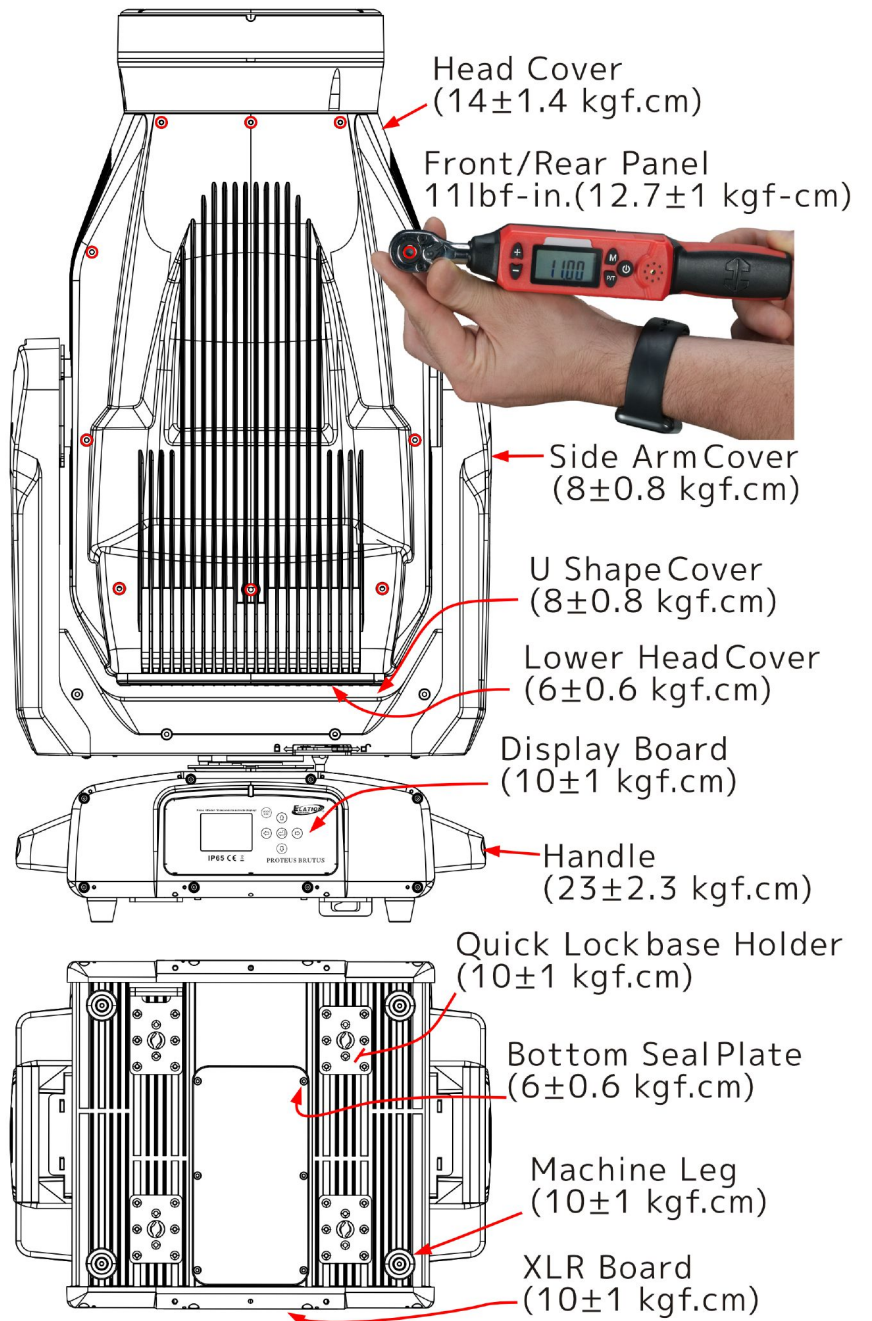

| IP PRESSURE TESTING PARAMETERS | | | |
|--------------------------------|-----------------------|------------------------|-----------|
| Test Type | Low Pressure Limit | High Pressure Limit | Hold Time |
| Vacuum Test | -4.35psi (-30.00 KPa) | -5.08 psi (-35.00 KPa) | 10s |
| Pressure Test | 3.62 psi (25.00 KPa) | 4.35 psi (30.00 KPa) | 10s |

FAN CONTROL AND LOW NOISE OPERATION

The Proteus Brutus is a high-performance fixture suited for multiple applications. For noise critical environments such as Theater, Opera, or Orchestral Halls, it offers various fan operation modes which remove unwanted noise distractions for the audience and performers. Fan Modes can be changed remotely via the DMX control channel, allowing the fixture to offer high output or whisper-silent operation at a moment's notice. All Fan Modes smoothly transition over a

| Mode | dbA at 1m LED off | dbA at 1m Dimmer 100% |
|------------------------------|-------------------|-----------------------|
| Fan Control - Auto (Default) | 39 | 46 |
| Fan Control - High | 50 | 59 |
| Fan Control - Low | 38 | 40 |
| Low Noise – Studio | 34 | 37 |
| Low Noise – Mute | 32 | 33 |

Auto (Default) – Fans only run at the speeds needed to keep the LED engine within a safe temperature range, and ensures optimal performance of the fixture. They will turn off if possible; for example, when the fixture is dimmed to a low intensity. Fans sense the ambient and fixture temperature and will, at all times, try to keep noise levels at a minimum. The fixture output will only be reduced when the LED engine cannot be cooled to its safe operating range due to a high ambient temperature.

NOTE: This mode is recommended for daily operation.

High – Fan speeds are increased throughout the fixture for the most efficient cooling. This mode will increase wear on the fans and should only be utilized in exceptional circumstances. Fans will always run, even if the fixture is dimmed. Fixture output is kept at 100% unless the LED engine temperature reaches an unsafe temperature, at which point the fixture will reduce power carefully to ensure continued safe operation. This mode is only required in very high ambient temperatures when automatic fan speed adjustments are not desired.

Low – For very critical noise environments, the fixture offers this mode, and two additional Low Noise Modes for silent operation: Studio and Mute. In Low mode, the fixture output will be reduced, yet due to the extremely high luminous flux, the fixture still offers outstanding performance. In Low Noise Mode, all parameters of the fixture operate more quietly with reduced fan speeds.

Studio – Fan speeds are reduced throughout the fixture for a lower noise profile. The fixture output is also reduced to approximately 80%. This mode should be sufficient for most uses where lower noise is required.

Mute – All but one fixture fan is turned off for whisper-quiet operation. The fixture LED power output is reduced to 25%.

INSTALLATION GUIDELINES



FLAMMABLE MATERIAL WARNING

Keep fixture minimum 5.0 feet (1.5m) away from flammable materials and/or pyrotechnics.



ELECTRICAL CONNECTIONS

A qualified electrician should be used for all electrical connections and/or installations.



USE CAUTION WHEN POWER LINKING OTHER MODEL FIXTURES AS THE POWER CONSUMPTION OF OTHER MODEL FIXTURES MAY EXCEED THE MAX POWER OUTPUT ON THIS FIXTURE. CHECK SILK SCREEN FOR MAX AMPS.



MINIMUM DISTANCE TO OBJECTS/SURFACES MUST BE 1.6 FOOT (0.5 METERS)



MINIMUM DISTANCE OF INFLAMMABLE MATERIALS FROM THE SURFACE 1.6 FEET (0.5 METER)



MAXIMUM AMBIENT TEMPERATURE 194° F (90°C)



DO NOT INSTALL THE FIXTURE IF YOU ARE NOT QUALIFIED TO DO SO!

Fixture **MUST** be installed following all local, national, and country commercial electrical and construction codes and regulations.

Before rigging/mounting the fixture to any metal truss/structure or placing the fixture on any surface, a professional equipment installer **MUST** be consulted to determine if the metal truss/structure or surface is properly certified to safely hold the combined weight of the fixture, clamps, cables, and accessories.

Overhead rigging requires extensive experience, including, amongst others, calculating working load limits, installation material being used, and periodic safety inspection of all installation material and the fixture. If you lack these qualifications, do not attempt the installation yourself. Improper installation can result in bodily injury.

Fixture ambient operating temperature range is **-4° to 113°F. (-20° to 45°C)**.

Do not use the fixture under or above this temperature.

Fixture should be installed in areas outside walking paths, seating areas, or away from areas where unauthorized personnel might reach the fixture by hand.

NEVER stand directly below the fixture when rigging, removing or servicing.

Overhead fixture installation must always be secured with a secondary safety attachment, such as an appropriately rated safety cable.

Allow approximately 10 minutes for the fixture to cool down before serving.

INSTALLATION GUIDELINES

OMEGA BRACKETS WITH CLAMP INSTALLATION

Insert the Omega Brackets into the matching holes on the bottom of the fixture. Secure the Omega Brackets to the fixture by turning each quick-lock fastener 1/4 turn clockwise; making sure the fastener is completely locked. Omega Brackets can be installed into the fixture base as illustrated below.

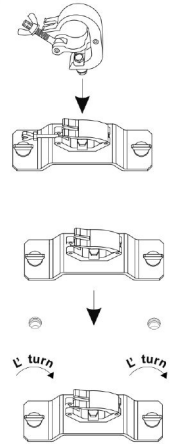

Omega Bracket Installation Steps

1. Attached appropriately rated clamps onto both Omega Brackets.
2. Insert Omega Brackets into matching mounting holes.
3. Turn both Quick-Lock Fasteners 1/4 turn clockwise to secure.

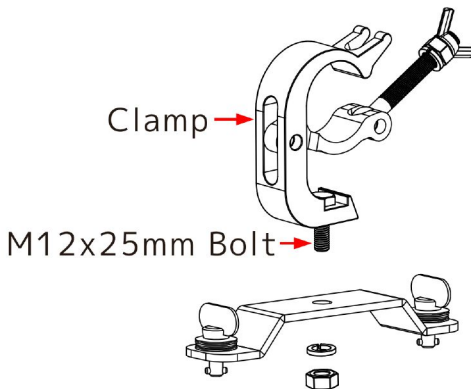

Attach Safety Cable Here!

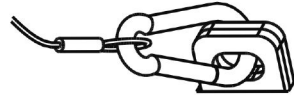

**Minimum Requirements:
12-Fold Weight Quick Link
Shackle with Hook**



SAFETY CABLE
ALWAYS ATTACH AN APPROPRIATELY RATED SAFETY CABLE WHENEVER INSTALLING THIS FIXTURE IN A SUSPENDED ENVIRONMENT TO ENSURE THE FIXTURE WILL NOT FALL IF THE CLAMP FAILS.

PROFESSIONAL USE ONLY! Read user manual completely before installation and use. **UNPLUG POWER BEFORE SERVICING FIXTURE!** DO NOT PLUG FIXTURE INTO A DIMMER PACK! NEVER TOUCH FIXTURE DURING OPERATION, AS IT MAY BE HOT! NEVER LOOK DIRECTLY INTO THE LIGHT SOURCE! SENSITIVE PERSONS MAY SUFFER AN EPILEPTIC SHOCK! Luminaire shall only be used with all protective covers and shields. Replace all damaged covers and shields. Maintenance and service operations by authorized dealers only!

MOUNTING THE FIXTURE ON A TRUSS USING CLAMPS WITH OMEGA BRACKETS

When mounting the fixture to a truss, be sure to secure an appropriately rated professional grade rigging clamp to the included **Omega Brackets** using an M10 screw fitted through the center hole of the **Omega Brackets**. The fixture provides built-in rigging points for a **SAFETY CABLE** (not included). Be sure to only use one of the designated rigging points for the safety cable and never secure a safety cable to a carrying handle.

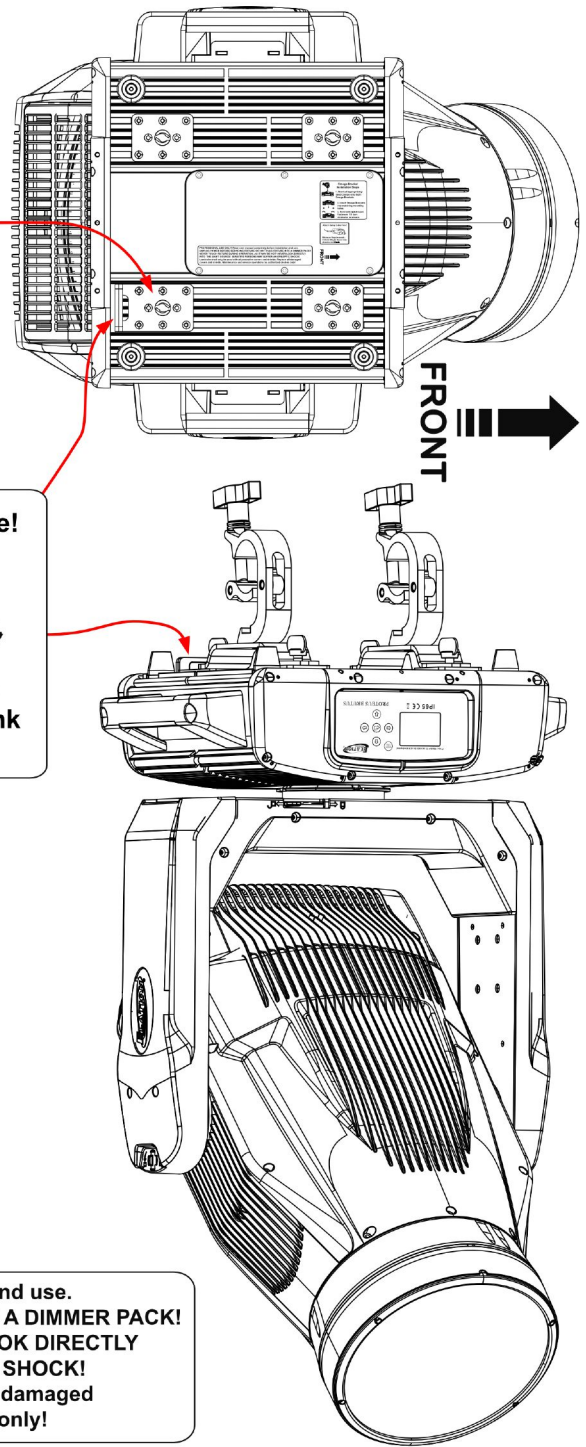

INSTALLATION GUIDELINES

RIGGING

Overhead rigging requires extensive experience, including among others calculating working load limits, installation material being used, and periodic safety inspection of all installation material and the fixture. If you lack these qualifications, do not attempt the installation yourself. Improper installation can result in bodily injury.

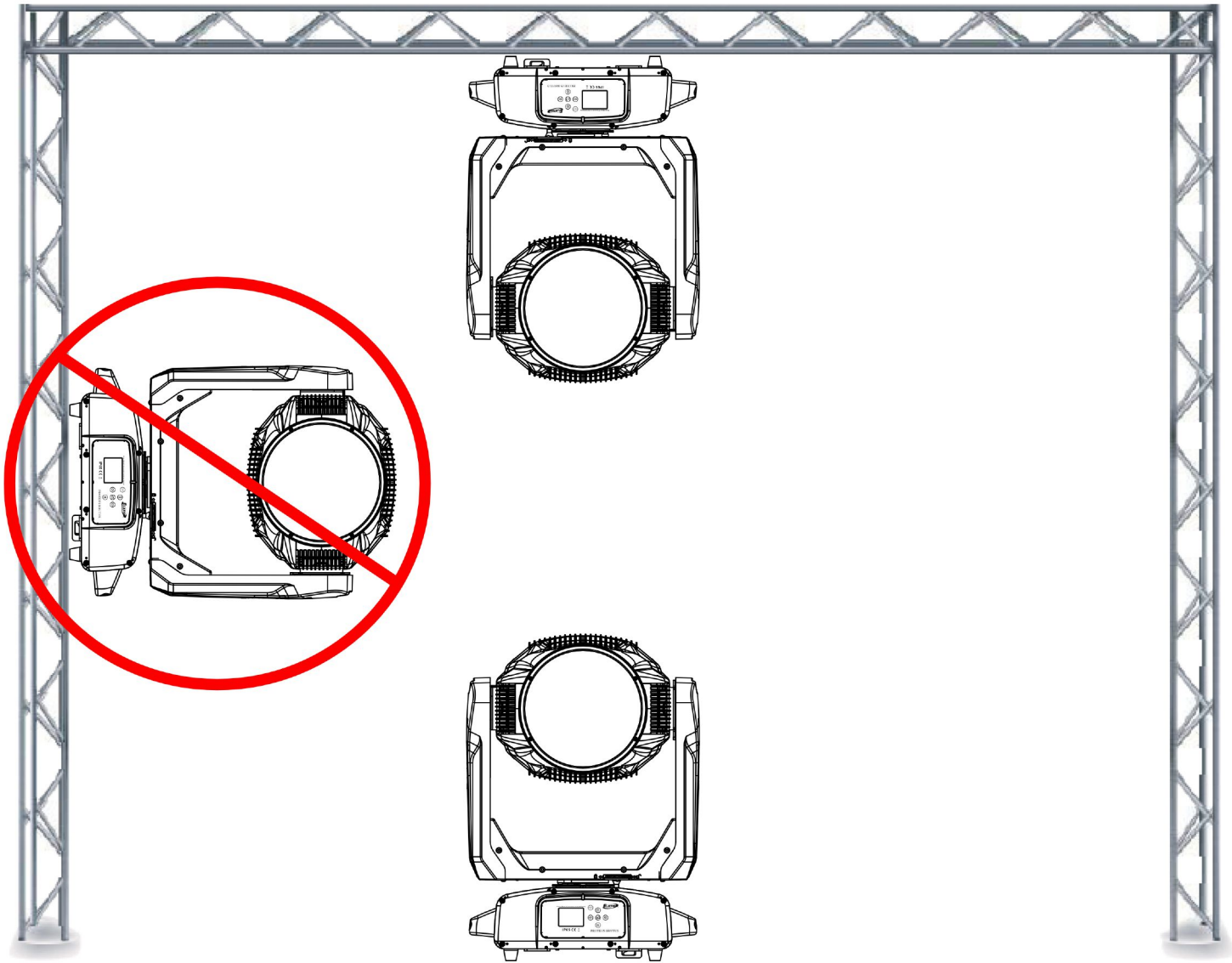

INSTALLATION GUIDELINES

ART-NET | sACN CONNECTION

When connecting fixture to a network switch to control multiple devices, a **Gigabit Ethernet Switch** that supports **IGMP (Internet Group Management Protocol)** is required. Using a **Gigabit Ethernet Switch** that does not support **IGMP** can cause erratic behavior of all connected devices to the switch. Click link below for more information about IGMP.

https://en.wikipedia.org/wiki/Internet_Group_Management_Protocol

POWER AND DATA CABLES



ENSURE ALL CONNECTIONS AND ENDCAPS ARE PROPERLY SEALED WITH DIELECTRIC GREASE (AVAILABLE AT MOST ELECTRICAL SUPPLIERS) TO PREVENT WATER CORROSION AND/OR ELECTRICAL SHORT CIRCUIT.



TO MAINTAIN THE IP65 RATING INTEGRITY OF THE FIXTURE AND PREVENT WATER FROM ENTERING THE FIXTURE, SEAL ALL UNUSED CONNECTION RUBBER CAPS.

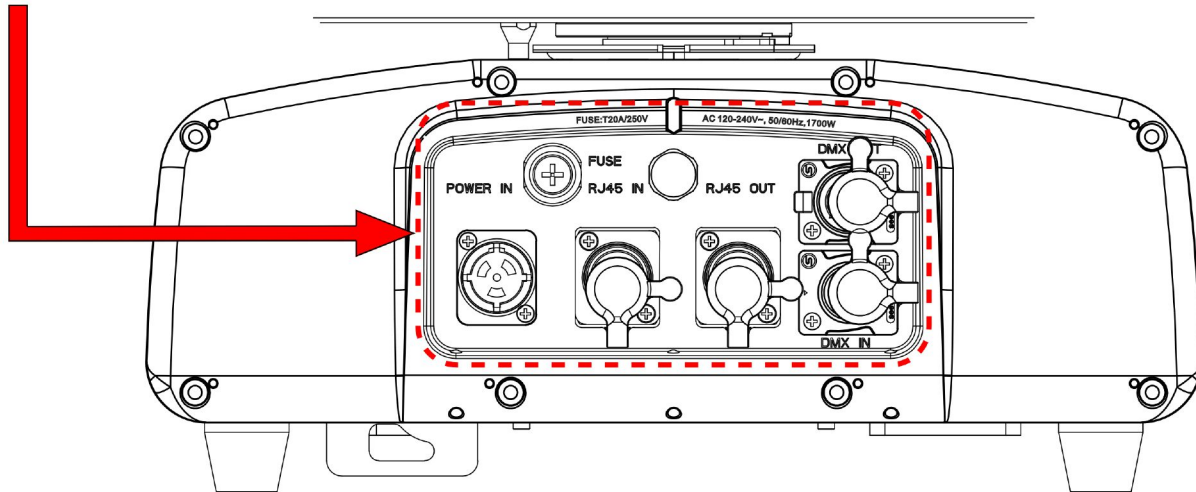

INCLUDED RJ45 DATA CABLE



THE INCLUDED RJ45 DATA CABLE IS FOR FIXTURE TO FIXTURE INTERCONNECTION ONLY! THE RJ45 CABLE CONNECTORS MAY NOT BE COMPATIBLE WITH OTHER RJ45/ETHERCON TYPE CONNECTORS.

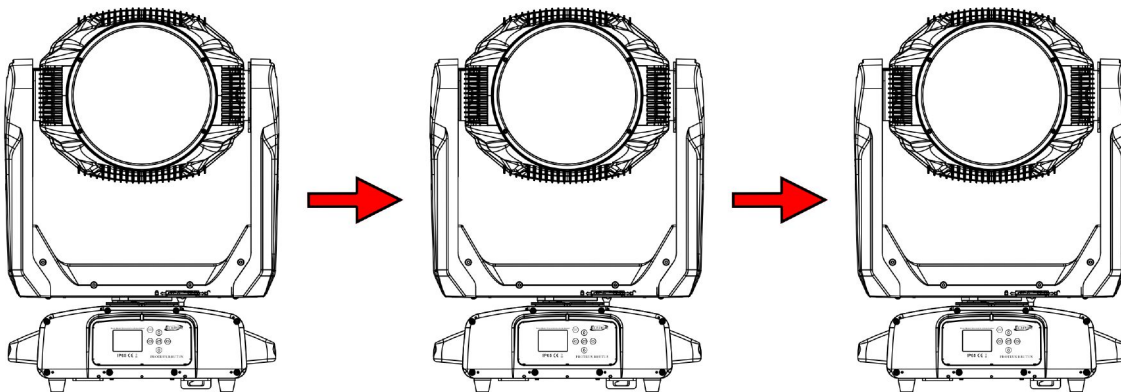

INSTALLATION GUIDELINES

POTENTIAL INTERNAL FIXTURE DAMAGE FROM EXTERNAL SOURCES OF LIGHT BEAMS

External sources of light beams from direct sunlight, lighting moving head fixtures, and lasers, which are focused directly towards the exterior housing and/or penetrate the front lens opening of ELATION lighting fixtures, can cause severe internal damage including burning to optics, dichroic color filters, glass and metal gobos, prisms, animation wheels, frost filters, iris, shutters, motors, belts, wiring, discharge lamps, and LEDs.

This issue is not specific only to ELATION lighting fixtures, it is a common issue with lighting fixtures from all manufacturers. Although there is no true way to fully prevent this issue from happening, the guidelines below can prevent any potential damage from occurring if followed. Contact ELATION Service for more details.

DO NOT EXPOSE THE FIXTURE AND/OR FRONT LENS OPENING TO LIGHT BEAMS FROM DIRECT SUNLIGHT, OTHER LIGHTING MOVING HEAD FIXTURES, AND LASERS WHILE UNPACKING, INSTALLATION, USE, AND EXTENDED IDLE TIMES OUTDOORS. DO NOT FOCUS A LIGHT BEAM FROM ONE LIGHTING FIXTURE DIRECTLY TOWARDS ANOTHER.

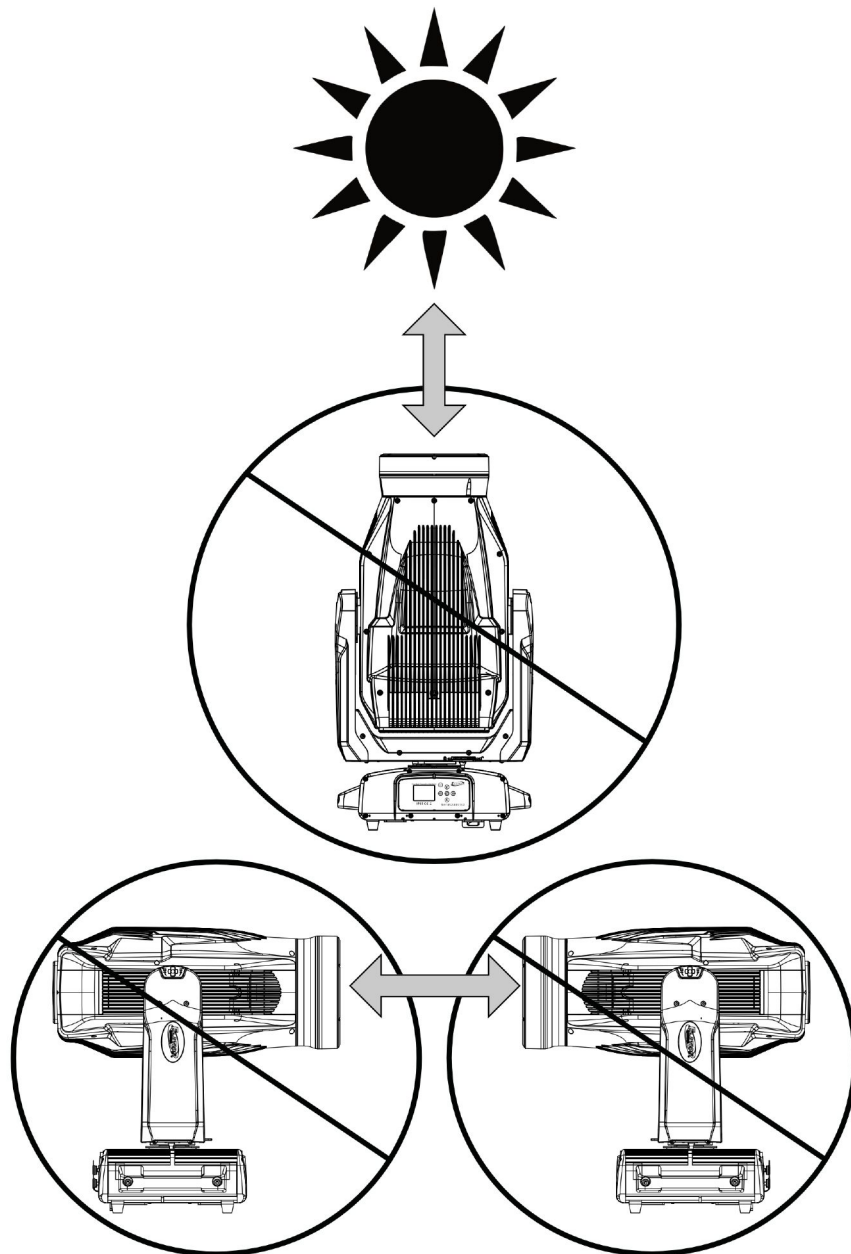

SUN PROTECTION MODE

The fixture incorporates an automatic protection from harmful sunlight, which can damage a fixture's internal components from extended exposure. Fixtures use an internal sensor to determine their physical orientation, then reorient the fixture towards the ground to prevent sunlight from entering the lens.

This automatic feature only works when the fixture is powered. If the fixture is unpowered during setup, it is necessary to manually reorient the lenses away from the sun, and aim them towards the ground. Even a few minutes of sun exposure can cause damage inside the fixture.

The Sun Protection setting is accessed via the "No DMX Status" menu.

The automatic sun protection positioning is activated under the following conditions:

1. Power on without DMX signal: the fixture always starts in sun protection mode.
2. No DMX Status "Sun Protection": the fixture enters sun protection mode after approximately 3 minutes.
3. Remote DMX control: the sun protection position can be **temporarily** activated from the lighting console without the need to create a custom position preset. The fixture senses the correct ground orientation. This means that fixtures already facing the ground may not move their heads.

Hold "Sun Protect Position" for 3s to set the fixture to the sun protection position.

Sun protection status displays as "**Sun Protection: Active**".

The sun protection position deactivates under the following conditions:

1. Connect DMX signal.
2. Remote DMX control: Hold "Sun Protection Off" for 3s.

To avoid harsh or jarring movements, the sun protection position always uses a 5-second fade time when it is activated or deactivated.

HIBERNATION MODE

To reduce wear on the fixture and its components, this mode disables motors and most electronics. Set the hibernation mode countdown time in the Display Menu: "Status Settings / Personality / Hibernation". Hibernation can be fully disabled.

The hibernation mode activates under the following conditions:

1. Loss of DMX: the fixture enters hibernation after the timeout expires. Default is 15 minutes.
2. Remote DMX control: Hold "Hibernate Fixture" for 3s

The hibernation mode deactivates under the following conditions:

1. Connect DMX Signal
2. Remote DMX control: Hold "Hibernate Off" for 3s

The fixture will perform a full calibration cycle, then assume the current DMX status.

Please note that the Hibernation does not change the PT position of the fixtures, allowing the user to set the desired position and then issue the Hibernate command.

To ensure the fixture is protected from harmful sunrays it is recommended to either leave the "No DMX Status" in "Sun Protection" (so the fixture is already in the correct position after 3 minutes of DMX loss) or set the fixture to a safe Tilt position manually first before hibernation.

Burn and heat damage to the fixture's interior components due to external light sources (sun or other fixtures shining into the lens) is never covered under the manufacturers warranty.

SYSTEM MENU

The fixture includes an easy to navigate system menu. The control panel (see image below) located on the front of the fixture, provides access to the main system menu and is where all necessary system adjustments are made to the fixture. During normal operation, pressing **MODE/ESC** button once will access the fixture's main menu. Once in the main menu you can navigate through the different functions and access the sub-menus with the **UP, DOWN, RIGHT,** and **LEFT** buttons. Once you reach a field that requires adjusting, press the **ENTER** button to activate that field and use the **UP** and **DOWN** buttons to adjust the field. Pressing the **ENTER** button once more will confirm your setting. You may exit the main menu at any time without making any adjustments by pressing the **MODE/ESC** button.

NOTE: To access the LCD Menu Control Display via the internal battery, press and hold the **MODE/ESC** button for 10 seconds. The LCD Menu Control Display will shut **OFF** automatically about 1 minute from the last button press.

NOTE: The unit comes with a battery so that the menu options can be changed or setup without the need to plug the unit into power.

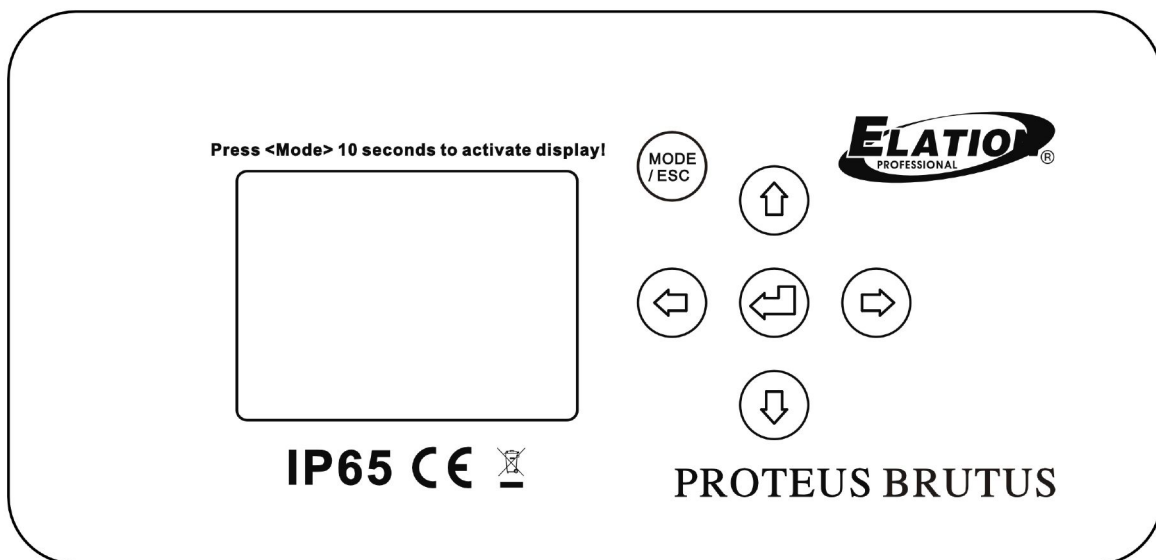

AN ELATION E-LOADER III CAN BE USED TO UPDATE THE FIXTURE TO THE LATEST SOFTWARE. TO ORDER THIS DEVICE, PLEASE CONTACT ELATION SUPPORT FOR FURTHER DETAILS.

**ELATION SERVICE USA - Monday - Friday 8:00am to 4:30pm PST
323-582-3322 | Fax 323-832-9142 | support@elationlighting.com**

**ELATION SERVICE EUROPE - Monday - Friday 08:30 to 17:00 CET
+31 45 546 85 63 | Fax +31 45 546 85 96 | support@elationlighting.eu**

SYSTEM MENU

| MAIN MENU | OPTIONS / VALUES (Default Settings in BOLD) | | DESCRIPTION | |
|--------------------|---|---|--|--------------------------|
| Function | Set Dmx Address | A001~Axxx | DMX Address Setting | |
| | Dmx Value | | DMX Value Display | |
| | Secondary Mode | Secondary1, Secondary2, Secondary3 | Secondary Setting | |
| | Auto Program | Primary / Alone | Auto Program | |
| Information | Time Information | Current Time | XXXX(Hours) | Power On Running Time |
| | | Total Run Time | XXXX(Hours) | Fixture Running Time |
| | | Last Run Time | XXXX(Hours) | Fixture Last Times Clear |
| | | LastRun Password | Password=XXX | Timer Password 038 |
| | | Clear Last Run | ON/OFF | Clear Fixture Last Time |
| | Temperature Info | LED Temperature | XXX°C/°F | Temperature in LED |
| | | Base Temperature | XXX°C/°F | Temperature in Base |
| | | Head Temperature | XXX°C/°F | Temperature in Fixture |
| | Humidity Info | Base Humidity | XXX% | Humidity in Base |
| | | Head Humidity | XXX% | Humidity in Fixture |
| | Ethernet IP | Ethernet IP XXX. XXX. XXX. XXX XXX. XXX. XXX. XXX | Ethernet IP | |
| | Fan Info | HeadFan1: xxxx RPM | Fan information | |
| | Software Version | 1U01: Vx.x.x 2U01: Vx.x.x | | |
| | Error Info | Error Record 1 Error Record 2 Error Record 10 | PAN..... PAN..... PAN..... | |
| Current RU Info | Iris Unit/Blade Unit | Replaceable Unit Info | | |
| Personality | Status Settings | Address Via DMX | ON/OFF | Address Via DMX |
| | | No DMX Status | Close/Hold/Auto | Auto Run If No DMX |
| | | Pan Reverse | ON/OFF | Pan Reverse movement |
| | | Tilt Reverse | ON/OFF | Tilt Reverse movement |
| | | Pan Degree | 630/540 | Pan Degree Select |
| | | Feedback | ON/OFF | Movement Feedback |
| | | Movement Speed | Normal/Slow | Movement Speed |
| | | CMY Speed | Normal/Fast | CMY Speed |
| | | P/T Brake Mode | Smooth/Fast | P/T Brake Mode |
| | | Hibernation | OFF, 01M~99M, 15M | Standby Mode |
| | Service Setting | Password | Password=XXX | Password"=050" |
| | | Clear Err. Info | ON/OFF | Clear Err. Info |
| | Fans Control | Auto /High/Low/Studio/Mute | Fans Control | |
| | Display Setting | Shutoff Time | 02~60m 05m | Display Shut Off Time |
| Display Reverse | | OFF/ON/ AUTO | Reverse 180 degree | |
| Key Lock | | ON/OFF | LCD Control Panel Key Lock | |

SYSTEM MENU

| MAIN MENU | OPTIONS / VALUES (Default Settings in BOLD) | | DESCRIPTION | |
|-----------------|---|---|--|-----------------|
| Personality | Temperature C/F | Celsius | Temp C/F | |
| | | Fahrenheit | | |
| | Initial Status | PAN =XXX | Initial effect position | |
| | Select Signal | DMX Only | Select Signal | |
| | | Art-Net | | |
| | | sACN | | |
| | Ethernet IP | XXX. XXX. XXX. XXX | Ethernet IP | |
| | Ether Mask IP | XXX. XXX. XXX. XXX | Ether Mask IP | |
| | Set Universe | 000~32767 | Setting Art-Net Universe | |
| | DHCP | ON/OFF | DHCP | |
| | Dimmer Mode | Standard | Dimmer Mode | |
| | | Stage | | |
| TV | | | | |
| Architectural | | | | |
| Theatre | | | | |
| Stage2 | | | | |
| Refresh | 1200 , 900-1500,, 2500, 4000, 5000, 6000, 10000, 15000, 20000, 25000(Hz) | Refresh Frequency Rate Setting | | |
| DimmerCurve | Linear , Square, Inverse Square, S-Curve | DimmerCurve Setting | | |
| ResetDef | ON | PassCode (11) | Restore factory settings Password = " 11 " | |
| | Off | | | |
| Reset Function | Reset All | | Reset Function | |
| | Reset Pan&Tilt | | | |
| | Reset Colors | | | |
| | Reset Gobos | | | |
| | ResetZoomModules | | | |
| | Reset Others | | | |
| Effect Adjust | Test Channel | Pan... | Test function | |
| | Manual Control | Pan = XXX : | Fine adjustment of the lamp | |
| | Calibration | Calibrate Password Pan=XXX : | Password = " 050 " Calibrate and adjust the effects to standard/right position | |
| User Mode | User Mode | Standard Mode Extended Mode | User's mode to change channel numbers | |
| Edit Program | Select Program | Auto Pro Part 1 = Program 1 ~ 10 Program 1 | Select Programs To Be Run | |
| | | Auto Pro Part 2 = Program 1 ~ 10 Program 1 | | |
| | | Auto Pro Part 3 = Program 1 ~ 10 Program 1 | | |
| | Edit Program | Prog 1 : Prog 10 | ProgTest | Testing Program |
| | | | Step 01 = SCxxx | Program In Loop |
| | | | STep 64 = SCxxx | Save and Exit |
| Edit Scenes | Scene 001 ~ Scene 250 | Pan, Tilt, - Fade Time - - Scene Time - Input By Out | Save and Automatically Return Manual Scenes Edit | |
| Rec. Controller | XX~XX | | Automatic Scenes Recorder | |

SYSTEM MENU

FUNCTION - Auto Program

Define fixture mode (**Primary or Alone**) for running Auto Programs. Select desired internal programs under "**Select Program**", set the number of steps under "**Edit program**", and edit individual scenes under "**Edit Scenes**".

PERSONALITY - Status Settings - Address Via DMX

When ON, define the desired DMX address via an external controller.

NOTE: This process assumes the fixture DMX address is set to 001. If fixture DMX address is not at 001, you must adjust the channel numbers accordingly in order for this feature to work.

For example: if your fixture address is 010, then Channel 1 becomes Channel 10, Channel 2 becomes Channel 11, and Channel 3 becomes Channel 12.

1. Connect the fixture to the external controller and power **ON**.
2. Set the DMX value of **Channel 1** on the controller to (7).
3. Set the DMX value of **Channel 2** on the controller to (7) or (8). When set to (7), the DMX address can be set between (1) and (255). When set to (8), the DMX address can be set between (256) and (511).
4. Using **Channel 3** on the controller set the desired DMX address of the fixture.

Example 1:

If the desired DMX address is **57**, set **Channel 1** to a value of (7), set **Channel 2** to a value of (7), and then set **Channel 3** to a value of (57).

Example 2:

If the desired DMX address is **420**, set **Channel 1** to a value of (7), set **Channel 2** to a value of (8), and then set **Channel 3** to a value of (164). ($256+164=420$)

5. After setting **Channel 3** to the desired DMX address value, wait approximately 20 seconds for the fixture to complete the address reset function.

PERSONALITY - Service Settings - Password (050)

NOTE: The Service Password MUST be entered in order to access the following menus:

Clear Err. Info.

PERSONALITY - Display Setting - Key Lock

When **ON**, Control Panel buttons lock automatically after exiting main menu for 15 seconds. To unlock, keep **MODE/ESC** button pressed for 3 seconds.

PERSONALITY - Dimmer Curve

Select dimming curve (Linear, Square, InverseSquare, S-Curve).

PERSONALITY - Reset Default (011)

SYSTEM MENU



ONLY QUALIFIED TECHNICIANS SHOULD PERFORM THIS FUNCTION!
NOTE: SAVED WHITE BALANCE IS ERASED AFTER A RESET IS PERFORMED!

This function restores all fixture settings to the factory default settings. The password is 011 and must be entered each time a reset is performed.

EFFECT ADJUST - Test Channel

Auto test each individual channel function independently from the DMX control board.

EFFECT ADJUST - Manual Control

Select and manually test and fine adjust each individual channel function Independently from DMX control board. This function will center PAN and TILT motors and set dimmer to 100%. PAN and TILT functions will still operate if the fixture needs to be positioned to a flat clear surface. With the individual functions, you can focus the light on a flat surface (wall) and perform fine adjustments.



EFFECT ADJUST - Calibration
ONLY QUALIFIED TECHNICIANS SHOULD PERFORM THIS FUNCTION.

This function allows small adjustments to be made to the Pan, Tilt, and Zoom movements to compensate for wear or in the event a sensor has been knocked slightly out of place. Because improper use of this function can result in undesired operation this function has been password protected. The password is 050 and must be entered each time the calibration menu function is entered. Because calibration is an extremely delicate procedure, instructions on performing this action are left out of this manual. For a first-time calibrator, please contact our customer support team for step-by-step instructions.

EDIT PROGRAM - Rec. Controller

The fixture features an integrated DMX-recorder by which you can transmit the programmed scenes from your DMX-controller to the moving head. Adjust the desired scene numbers via the encoder (from – to). When you call up the scenes at your controller, they will automatically be transmitted to the moving head.

SYSTEM MENU

EDIT PROGRAM - Record Controller - Working With Built - In Programs

A Primary unit can send up to 3 different data groups to the Secondary units, i.e. a Primary unit can start 3 different Secondary units, which run 3 different programs. The Primary unit sends the 3 program parts in a continuous loop.



The Secondary unit receives data from the Primary unit according to the group which the Secondary unit was assigned to. If e.g. a Secondary unit is set to **“Secondary 1”** in the menu **“Set to Secondary”**, the Primary unit sends **“Auto Program Part 1”** to the Secondary unit. If set to **“Secondary 2”**, the Secondary unit receives **“Auto Program Part 2”**.

To start an Auto Program proceed as follows:

1. Secondary Setting

- Select **“Function Mode”**.
- Press **ENTER** to confirm.
- Select **“Set to Secondary”**.
- Press **ENTER** to confirm.
- Select **“Secondary 1”**, **“Secondary 2”** or **“Secondary 3”**.
- Press **ENTER** to confirm.
- Press **MODE/ESC** in order to return to the main menu.

2. Automatic Program Run

- Select **“Function Mode”**.
- Press **ENTER** to confirm.
- Select **“Auto Program”**.
- Press **ENTER** to confirm.
- Select **“Primary”** or **“Alone”**.
- Press **ENTER** to confirm.
- Press **MODE/ESC** in order to return to the main menu.

SYSTEM MENU

EDIT PROGRAM - Record Controller - Working With Built-In Program [continued]

3. Program Selection for Auto Pro Part

- Select "Edit Program".
- Press **ENTER** to confirm.
- Select "Select Programs".
- Press **ENTER** to confirm.
- Select "Auto Pro Part 1", "Auto Pro Part 2" or "Auto Pro Part 3", and select which Secondary program is to be sent. Selection "Part 1" means, that the Secondary unit runs the same program as the Primary units.
- Press **ENTER** to confirm.
- Press **MODE/ESC** in order to return to the main menu.

4. Program Selection for Edit Program

- Select "Edit Program".
- Press **ENTER** to confirm.
- Select "Edit Program".
- Press **ENTER** to confirm.
- Select the desired program to edit specific scenes into a specific program.
- Press **ENTER** to confirm.
- Press **MODE/ESC** in order to return to the main menu.

5. Automatic Scene Recording

- Select "Edit Program".
- Press **ENTER** to confirm.
- Select "Edit Scenes".
- Press **ENTER** to confirm.
- Select desired scene numbers. A maximum of 250 scenes can be programmed.
- Press **ENTER** to confirm.
- Press **MODE/ESC** in order to return to the main menu.

EDIT PROGRAM - Record Controller - Working With Built - In Program [continued]

Example:

Program 2 includes scenes: 10, 11, 12, & 13

Program 4 includes scenes: 8, 9, & 10

Program 6 includes scenes: 12, 13, 14, & 15

Auto Pro Part 1 is Program 2

Auto Pro Part 2 is Program 3

Auto Pro Part 3 is Program 6

The 3 Secondary groups run the Auto Program in certain time segments.

Part 1

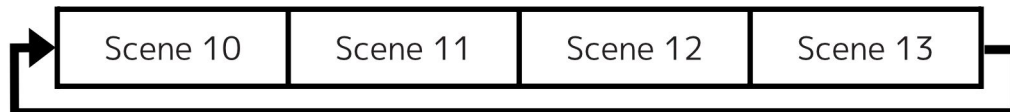

Part 2



Part 3

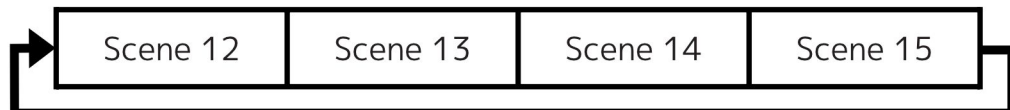

DIMMER MODE

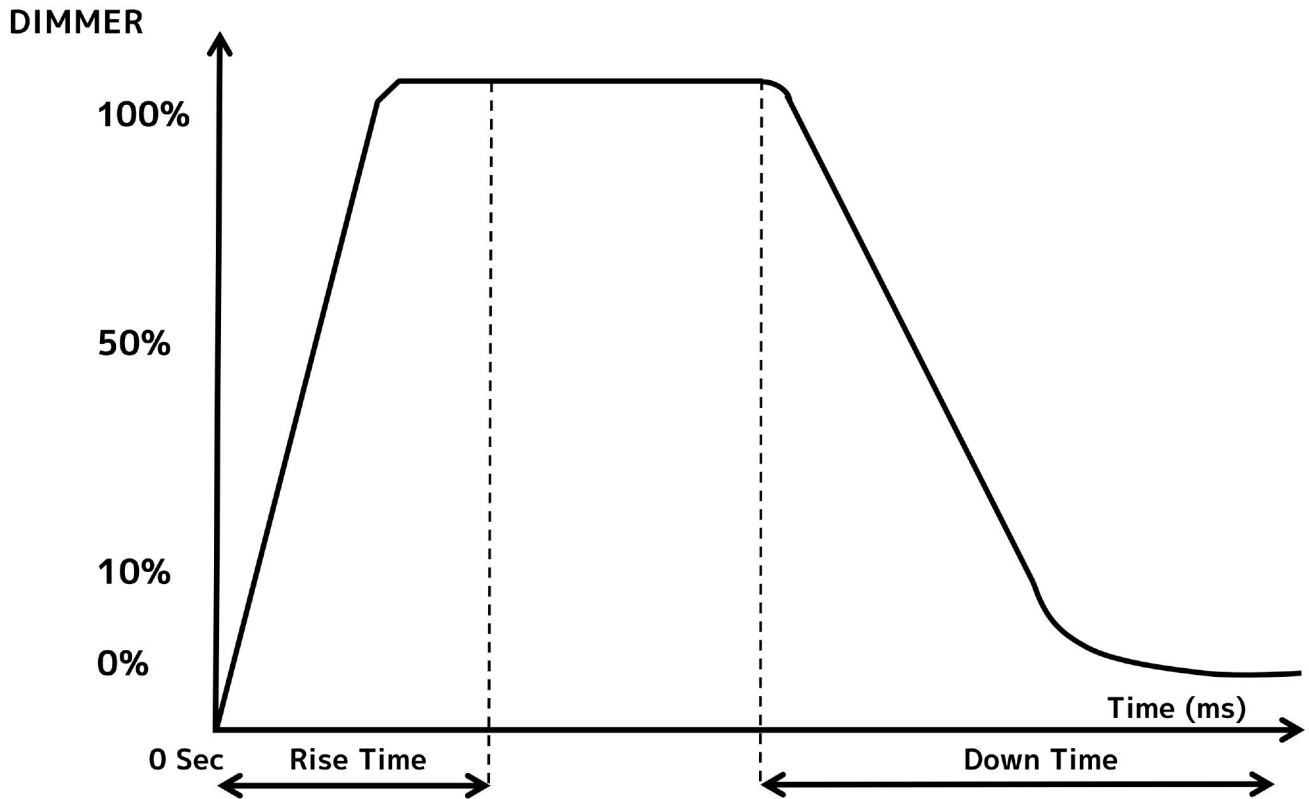

| Dimming Curve Ramp Effect | 0 sec Fade Time | | 1 sec Fade Time | |
|------------------------------|-----------------|----------------|-----------------|----------------|
| | Rise Time (ms) | Down Time (ms) | Rise Time (ms) | Down Time (ms) |
| Standard (default) | 0 | 0 | 0 | 0 |
| Stage | 780 | 1100 | 1540 | 1660 |
| TV | 1180 | 1520 | 1860 | 1940 |
| Architectural | 1380 | 1730 | 2040 | 2120 |
| Theatre | 1580 | 1940 | 2230 | 2280 |
| Stage 2 | 0 | 1100 | 0 | 1660 |

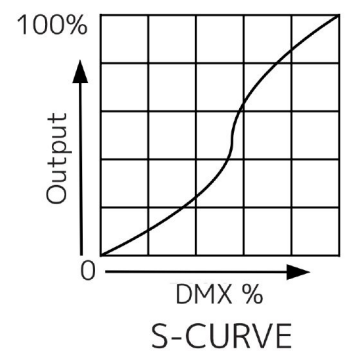
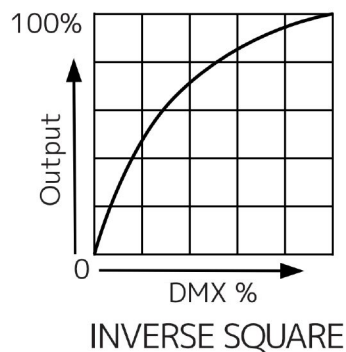
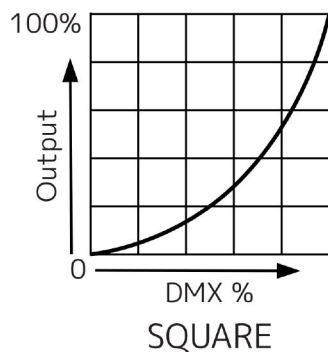
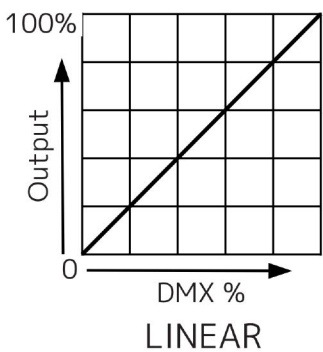

DMX TRAITS: CHANNEL FUNCTIONS & VALUES

Features subject to change without notice

| MODE/CHANNEL | | | | VALUE | FUNCTION | FADE STATUS | DEFAULT VALUE |
|--------------|-------------------------------|------------------|------------------|---------|---|-------------|---------------|
| STANDARD | EXTENDED | FRAMING STANDARD | FRAMING EXTENDED | | | | |
| 1 | 1 | 1 | 1 | 0-255 | Pan Movement | Fade | 127 |
| 2 | 2 | 2 | 2 | 0-255 | Pan Fine Fine Movement | Fade | 127 |
| 3 | 3 | 3 | 3 | 0-255 | Tilt Movement | Fade | 127 |
| 4 | 4 | 4 | 4 | 0-255 | Tilt Fine Fine Movement | Fade | 127 |
| 5 | 5 | 5 | 5 | 0-255 | Cyan 0 → 100% | Fade | 0 |
| | 6 | | 6 | 0-255 | Cyan Fine Fine Adjustment | Fade | 0 |
| 6 | 7 | 6 | 7 | 0-255 | Magenta 0 → 100% | Fade | 0 |
| | 8 | | 8 | 0-255 | Magenta Fine Fine Adjustment | Fade | 0 |
| 7 | 9 | 7 | 9 | 0-255 | Yellow 0 → 100% | Fade | 0 |
| | 10 | | 10 | 0-255 | Yellow Fine Fine Adjustment | Fade | 0 |
| 8 | 11 | 8 | 11 | 0-255 | CTO Cold → Warm | Fade | 0 |
| | 12 | | 12 | 0-255 | CTO Fine Fine Adjustment | Fade | 0 |
| 9 | 13 | 9 | 13 | | Color Wheel | Snap | 0 |
| | | | | 0-19 | Open | | |
| | | | | 20-37 | Red | | |
| | | | | 38-55 | Green | | |
| | | | | 56-73 | UV | | |
| | | | | 74-91 | HCRI | | |
| | | | | 92-109 | Orange | | |
| | | | | 110-127 | Medium Blue | | |
| | | | | | Color Scroll | | |
| | | | | 128-189 | Clockwise,fast → slow | | |
| 190-193 | Stop | | | | | | |
| 194-255 | Counter-clockwise,slow → fast | | | | | | |
| | 14 | | 14 | | Color Wheel Fine Fine Adjustment | Snap | 0 |
| 10 | 15 | 10 | 15 | | Rotating Gobo | Snap | 0 |
| | | | | 0-9 | Open | | |
| | | | | 10-19 | Gobo 1 | | |
| | | | | 20-29 | Gobo 2 | | |
| | | | | 30-39 | Gobo 3 | | |
| | | | | 40-49 | Gobo 4 | | |
| | | | | 50-59 | Gobo 5 | | |
| | | | | 60-69 | Gobo 6 | | |
| | | | | 70-89 | Gobo 1 Shake slow → fast | | |
| | | | | 90-109 | Gobo 2 Shake slow → fast | | |
| | | | | 110-129 | Gobo 3 Shake slow → fast | | |
| | | | | 130-149 | Gobo 4 Shake slow → fast | | |
| | | | | 150-169 | Gobo 5 Shake slow → fast | | |
| | | | | 170-189 | Gobo 6 Shake slow → fast | | |
| | Gobo Scroll | | | | | | |
| 190-221 | Clockwise,fast → slow | | | | | | |
| 222-223 | Stop | | | | | | |
| 224-255 | Counter-clockwise,slow → fast | | | | | | |
| 11 | 16 | 11 | 16 | | Rotating Gobo Index | Fade | 64 |
| | | | | 0-127 | Gobo Index | | |
| | | | | 128-189 | Clockwise,fast → slow | | |
| | | | | 190-193 | Stop | | |
| | 17 | | 17 | 0-255 | Rotating Gobo Index Fine Fine Adjustment | Fade | 127 |

DMX TRAITS: CHANNEL FUNCTIONS & VALUES

Features subject to change without notice

| MODE/CHANNEL | | | | VALUE | FUNCTION | FADE STATUS | DEFAULT VALUE |
|--------------|----------|------------------|------------------|---------|---|-------------|---------------|
| STANDARD | EXTENDED | FRAMING STANDARD | FRAMING EXTENDED | | | | |
| 13 | 18 | 13 | 18 | 0-255 | Focus Focus edge adjustment | Fade | 127 |
| 14 | 19 | 14 | 19 | 0-255 | Focus Fine Focus adjustment Fine | Fade | 127 |
| 15 | 20 | 15 | 20 | 0-255 | Zoom Narrow → Wide | Fade | 127 |
| 16 | 21 | 16 | 21 | 0-255 | Zoom Fine Fine Adjustment | Fade | 127 |
| | | | | | Auto Focus | | |
| | 22 | | 22 | 0-50 | Auto Focus Off | Snap | 0 |
| | | | | 51-100 | 5m | | |
| | | | | 101-150 | 7.5m | | |
| | | | | 151-200 | 10m | | |
| | | | | 201-255 | 15m | | |
| | 23 | | 23 | 0-255 | AutoFocus Fine Fine Adjustment | Snap | 0 |
| | | | | | Shutter | | |
| 17 | 24 | 17 | 24 | 0-31 | Closed | Snap | 50 |
| | | | | 32-63 | Open | | |
| | | | | 64-95 | Strobe slow → fast | | |
| | | | | 96-127 | Open | | |
| | | | | 128-159 | Pulse-effect | | |
| | | | | 160-191 | Open | | |
| | | | | 192-223 | Random strobe slow → fast | | |
| | | | | 224-255 | Open | | |
| 18 | 25 | 18 | 25 | 0-255 | Dimmer 0 → 100% | Fade | 0 |
| 19 | 26 | 19 | 26 | 0-255 | Dimmer Fine Fine Adjustment | Fade | 0 |
| | | | | | Dim Modes | | |
| | | | | 0-20 | Standard | Snap | 0 |
| | | | | 21-40 | Stage | | |
| | | | | 41-60 | TV | | |
| | | | | 61-80 | Architectural | | |
| | | | | 81-100 | Theatre | | |
| | | | | 101-120 | Stage 2 | | |
| | | | | | Dimmer Delay Time | | |
| 20 | 27 | 20 | 27 | 121 | 0s | | |
| | | | | 122 | 0.1s | | |
| | | | | 123 | 0.2s | | |
| | | | | 124 | 0.3s | | |
| | | | | 125 | 0.4s | | |
| | | | | 126 | 0.5s | | |
| | | | | 127 | 0.6s | | |
| | | | | 128 | 0.7s | | |
| | | | | 129 | 0.8s | | |
| | | | | 130 | 0.9s | | |
| | | | | 131 | 1.0s | | |
| | | | | 132 | 1.5s | | |
| | | | | 133 | 2.0s | | |
| | | | | 134 | 3.0s | | |
| | | | | 135 | 4.0s | | |
| | | | | 136 | 5.0s | | |
| | | | | 137 | 6.0s | | |
| | | | | 138 | 7.0s | | |
| | | | | 139 | 8.0s | | |
| | | | | 140 | 9.0s | | |
| | | | | 141 | 10s | | |
| | | | | 142-255 | Idle | | |

DMX TRAITS: CHANNEL FUNCTIONS & VALUES

Features subject to change without notice

| MODE/CHANNEL | | | | VALUE | FUNCTION | FADE STATUS | DEFAULT VALUE |
|--------------|----------|------------------|------------------|---------|---|-------------|---------------|
| STANDARD | EXTENDED | FRAMING STANDARD | FRAMING EXTENDED | | | | |
| 13 | 18 | 13 | 18 | 0-255 | Focus Focus edge adjustment | Fade | 127 |
| 14 | 19 | 14 | 19 | 0-255 | Focus Fine Focus adjustment Fine | Fade | 127 |
| 15 | 20 | 15 | 20 | 0-255 | Zoom Narrow → Wide | Fade | 127 |
| 16 | 21 | 16 | 21 | 0-255 | Zoom Fine Fine Adjustment | Fade | 127 |
| | | | | | Auto Focus | | |
| | | | | 0-50 | Auto Focus Off | | |
| | 22 | | 22 | 51-100 | 5m | Snap | 0 |
| | | | | 101-150 | 7.5m | | |
| | | | | 151-200 | 10m | | |
| | | | | 201-255 | 15m | | |
| | | | | | | | |
| | 23 | | 23 | 0-255 | AutoFocus Fine Fine Adjustment | Snap | 0 |
| | | | | | Shutter | | |
| | | | | 0-31 | Closed | | |
| | | | | 32-63 | Open | | |
| | | | | 64-95 | Strobe slow → fast | | |
| 17 | 24 | 17 | 24 | 96-127 | Open | Snap | 50 |
| | | | | 128-159 | Pulse-effect | | |
| | | | | 160-191 | Open | | |
| | | | | 192-223 | Random strobe slow → fast | | |
| | | | | 224-255 | Open | | |
| 18 | 25 | 18 | 25 | 0-255 | Dimmer 0 → 100% | Fade | 0 |
| 19 | 26 | 19 | 26 | 0-255 | Dimmer Fine Fine Adjustment | Fade | 0 |
| | | | | | Dim Modes | | |
| | | | | 0-20 | Standard | | |
| | | | | 21-40 | Stage | | |
| | | | | 41-60 | TV | | |
| | | | | 61-80 | Architectural | | |
| | | | | 81-100 | Theatre | | |
| | | | | 101-120 | Stage 2 | | |
| | | | | | Dimmer Delay Time | | |
| | | | | 121 | 0s | | |
| | | | | 122 | 0.1s | | |
| | | | | 123 | 0.2s | | |
| | | | | 124 | 0.3s | | |
| | | | | 125 | 0.4s | | |
| | | | | 126 | 0.5s | | |
| | | | | 127 | 0.6s | | |
| | | | | 128 | 0.7s | | |
| | | | | 129 | 0.8s | | |
| | | | | 130 | 0.9s | | |
| | | | | 131 | 1.0s | | |
| | | | | 132 | 1.5s | | |
| | | | | 133 | 2.0s | | |
| | | | | 134 | 3.0s | | |
| | | | | 135 | 4.0s | | |
| | | | | 136 | 5.0s | | |
| | | | | 137 | 6.0s | | |
| | | | | 138 | 7.0s | | |
| | | | | 139 | 8.0s | | |
| | | | | 140 | 9.0s | | |
| | | | | 141 | 10s | | |
| | | | | 142-255 | Idle | | |
| 20 | 27 | 20 | 27 | | | Snap | 0 |

DMX TRAITS: CHANNEL FUNCTIONS & VALUES

Features subject to change without notice

| MODE/CHANNEL | | | | VALUE | FUNCTION | FADE STATUS | DEFAULT VALUE |
|--------------|----------|------------------|------------------|---------|------------------------------------|-------------|---------------|
| STANDARD | EXTENDED | FRAMING STANDARD | FRAMING EXTENDED | | | | |
| | | | | | Iris | | |
| 21 | 28 | 21 | 28 | 0-191 | Open → Close | | |
| | | | | 192-223 | Pulse closing fast → slow | | |
| | | | | 224-255 | Pulse opening slow → fast | | |
| | 29 | | 29 | | Iris Fine Fine Adjustment | | |
| 22 | 30 | 22 | 30 | 0-255 | Frost Open → Max | | |
| | | | | | Animation wheel | | |
| 23 | 31 | 23 | 31 | 0-7 | Open | | |
| | | | | 8-255 | Min → Max | | |
| | | | | | Animation Index | | |
| 24 | 32 | 24 | 32 | 0-127 | Animation Index | | |
| | | | | 128-189 | Clockwise,fast → slow | | |
| | | | | 190-193 | Stop | | |
| | | | | 194-255 | Counter-clockwise,slow → fast | | |
| | 33 | | 33 | 0-255 | Color Macro Speed Max → Min | | |
| | | | | | Color Macro | | |
| | 34 | | 34 | 0-31 | Open | | |
| | | 32-39 | | Macro1 | | | |
| | | 40-47 | | Macro2 | | | |
| | | 48-55 | | Macro3 | | | |
| | | 56-63 | | Macro4 | | | |
| | | 64-71 | | Macro5 | | | |
| | | 72-79 | | Macro6 | | | |
| | | 80-87 | | Macro7 | | | |
| | | 88-95 | | Macro8 | | | |
| | | 96-103 | | Macro9 | | | |
| | | 104-111 | | Macro10 | | | |
| | | 112-119 | | Macro11 | | | |
| | | 120-127 | | Macro12 | | | |
| | | 128-135 | | Macro13 | | | |
| | | 136-143 | | Macro14 | | | |
| | | 144-151 | | Macro15 | | | |
| | | 152-159 | | Macro16 | | | |
| | | 160-167 | | Macro17 | | | |
| | | 168-175 | | Macro18 | | | |
| | | 176-183 | | Macro19 | | | |
| | | 184-191 | | Macro20 | | | |
| | | 192-199 | | Macro21 | | | |
| | | 200-207 | | Macro22 | | | |
| | | 208-215 | | Macro23 | | | |
| | 216-223 | Macro24 | | | | | |
| | 224-231 | Macro25 | | | | | |
| | 232-239 | Macro26 | | | | | |
| | 240-247 | Macro27 | | | | | |
| | 248-255 | Random CMY | | | | | |

DMX TRAITS: CHANNEL FUNCTIONS & VALUES

Features subject to change without notice

| MODE/CHANNEL | | | | VALUE | FUNCTION | FADE STATUS | DEFAULT VALUE |
|--------------|----------|------------------|------------------|---------|--|-------------|---------------|
| STANDARD | EXTENDED | FRAMING STANDARD | FRAMING EXTENDED | | | | |
| | | 25 | 35 | 0-255 | Blade 1A Open → Close | Fade | 0 |
| | | | | 0-255 | Blade 1A Fine Fine Adjustment | Fade | 0 |
| | | 26 | 37 | 0-255 | Blade 1B Open → Close | Fade | 0 |
| | | | | 0-255 | Blade 1B Fine Fine Adjustment | Fade | 0 |
| | | 27 | 39 | 0-255 | Blade 2A Open → Close | Fade | 0 |
| | | | | 0-255 | Blade 2A Fine Fine Adjustment | Fade | 0 |
| | | 28 | 41 | 0-255 | Blade 2B Open → Close | Fade | 0 |
| | | | | 0-255 | Blade 2B Fine Fine Adjustment | Fade | 0 |
| | | 29 | 43 | 0-255 | Blade 3A Open → Close | Fade | 0 |
| | | | | 0-255 | Blade 3A Fine Fine Adjustment | Fade | 0 |
| | | 30 | 45 | 0-255 | Blade 3B Open → Close | Fade | 0 |
| | | | | 0-255 | Blade 3B Fine Fine Adjustment | Fade | 0 |
| | | 31 | 47 | 0-255 | Blade 4A Open → Close | Fade | 0 |
| | | | | 0-255 | Blade 4A Fine Fine Adjustment | Fade | 0 |
| | | 32 | 49 | 0-255 | Blade 4B Open → Close | Fade | 0 |
| | | | | 0-255 | Blade 4b Fine Fine Adjustment | Fade | 0 |
| | | | | | Framing Index | | |
| | | | 51 | 0-126 | Min (-45°) | Fade | 127 |
| | | | | 127-128 | Parallel (0°) | | |
| | | | | 129-255 | Max (+45°) | | |
| | | | 52 | 0-255 | Framing IndexFine Fine Adjustment | Fade | 127 |
| | | | 53 | 0-255 | Framing Speed Max → Min | Fade | 0 |
| | | | | | Framing Macro | | |
| | | | | 0-7 | Open | Snap | 0 |
| | | | | 8-15 | Macro1 | | |
| | | | | 16-23 | Macro2 | | |
| | | | | 24-31 | Macro3 | | |
| | | | | 32-39 | Macro4 | | |
| | | | | 40-47 | Macro5 | | |
| | | | | 48-55 | Macro6 | | |
| | | | | 56-63 | Macro7 | | |
| | | | | 64-71 | Macro8 | | |
| | | | | 72-79 | Macro9 | | |
| | | | | 80-87 | Macro10 | | |
| | | | | 88-95 | Macro11 | | |
| | | | | 96-103 | Macro12 | | |
| | | | | 104-111 | Macro13 | | |
| | | | | 112-119 | Macro14 | | |
| | | | 54 | 120-127 | Macro15 | | |
| | | | | 128-135 | Macro16 | | |
| | | | | 136-143 | Macro17 | | |
| | | | | 144-151 | Macro18 | | |
| | | | | 152-159 | Macro19 | | |
| | | | | 160-167 | Macro20 | | |
| | | | | 168-175 | Macro21 | | |
| | | | | 176-183 | Macro22 | | |
| | | | | 184-191 | Macro23 | | |
| | | | | 192-199 | Macro24 | | |
| | | | | 200-207 | Macro25 | | |
| | | | | 208-215 | Macro26 | | |
| | | | | 216-223 | Macro27 | | |
| | | | | 224-231 | Macro28 | | |
| | | | | 232-239 | Macro29 | | |
| | | | | 240-247 | Macro30 | | |
| | | | | 248-255 | Macro31 | | |

DMX TRAITS: CHANNEL FUNCTIONS & VALUES

Features subject to change without notice

| MODE/CHANNEL | | | | VALUE | FUNCTION | FADE STATUS | DEFAULT VALUE |
|--------------|----------|------------------|------------------|---------|-------------------------------------|-------------|---------------|
| STANDARD | EXTENDED | FRAMING STANDARD | FRAMING EXTENDED | | | | |
| | 35 | | 55 | | Pan / Tilt Speed | Snap | 0 |
| | | | | 0-225 | Max → Min Speed | | |
| | | | | 226-235 | Blackout by movement | | |
| | | | | 236-245 | Blackout by wheel changes | | |
| | | | | 246-255 | No function | | |
| | | | | | Control | Snap | Snap |
| | | | | 0-19 | Color change normal | | |
| | | | | 20-29 | Color change to any position | | |
| | | | | 30-39 | Color & gobo change to any position | | |
| | | | | 40-44 | Low Noise - Mute | | |
| | | | | 45-49 | Low Noise - Studio | | |
| | | | | 50-54 | Fan Control - Low | | |
| | | | | 55-59 | Fan Control - High | | |
| | | | | 60-64 | Fan Control - Auto (Default) | | |
| | | | | 65-79 | Idle | | |
| | | | | 80-84 | All motor reset | | |
| | | | | 85-87 | Pan / Tilt reset | | |
| | | | | 88-90 | Color reset | | |
| | | | | 91-93 | Gobo reset | | |
| | | | | 94-96 | Focus and Zoom reset | | |
| | | | | 97-99 | Other motor reset | | |
| | | | | | Refresh Rate (Hz) | | |
| | | | | 100 | 900 | | |
| | | | | 101 | 910 | | |
| | | | | 102 | 920 | | |
| | | | | 103 | 930 | | |
| | | | | 104 | 940 | | |
| | | | | 105 | 950 | | |
| 25 | 36 | 34 | 56 | 106 | 960 | | |
| | | | | 107 | 970 | | |
| | | | | 108 | 980 | | |
| | | | | 109 | 990 | | |
| | | | | 110 | 1000 | | |
| | | | | 111 | 1010 | | |
| | | | | 112 | 1020 | | |
| | | | | 113 | 1030 | | |
| | | | | 114 | 1040 | | |
| | | | | 115 | 1050 | | |
| | | | | 116 | 1060 | | |
| | | | | 117 | 1070 | | |
| | | | | 118 | 1080 | | |
| | | | | 119 | 1090 | | |
| | | | | 120 | 1100 | | |
| | | | | 121 | 1110 | | |
| | | | | 122 | 1120 | | |
| | | | | 123 | 1130 | | |
| | | | | 124 | 1140 | | |
| | | | | 125 | 1150 | | |
| | | | | 126 | 1160 | | |
| | | | | 127 | 1170 | | |
| | | | | 128 | 1180 | | |
| | | | | 129 | 1190 | | |
| | | | | 130 | 1200 | | |

DMX TRAITS: CHANNEL FUNCTIONS & VALUES

Features subject to change without notice

| MODE/CHANNEL | | | | VALUE | FUNCTION | FADE STATUS | DEFAULT VALUE |
|--------------|-------------------------------|------------------|------------------|-------|-------------|-------------|---------------|
| STANDARD | EXTENDED | FRAMING STANDARD | FRAMING EXTENDED | | | | |
| 25 | 36 | 34 | 56 | 131 | 1210 | Snap | Snap |
| | | | | 132 | 1220 | | |
| | | | | 133 | 1230 | | |
| | | | | 134 | 1240 | | |
| | | | | 135 | 1250 | | |
| | | | | 136 | 1260 | | |
| | | | | 137 | 1270 | | |
| | | | | 138 | 1280 | | |
| | | | | 139 | 1290 | | |
| | | | | 140 | 1300 | | |
| | | | | 141 | 1310 | | |
| | | | | 142 | 1320 | | |
| | | | | 143 | 1330 | | |
| | | | | 144 | 1340 | | |
| | | | | 145 | 1350 | | |
| | | | | 146 | 1360 | | |
| | | | | 147 | 1370 | | |
| | | | | 148 | 1380 | | |
| | | | | 149 | 1390 | | |
| | | | | 150 | 1400 | | |
| | | | | 151 | 1410 | | |
| | | | | 152 | 1420 | | |
| | | | | 153 | 1430 | | |
| | | | | 154 | 1440 | | |
| | | | | 155 | 1450 | | |
| | | | | 156 | 1460 | | |
| | | | | 157 | 1470 | | |
| | | | | 158 | 1480 | | |
| | | | | 159 | 1490 | | |
| | | | | 160 | 1500 | | |
| | | | | 161 | 2500 | | |
| | | | | 162 | 4000 | | |
| | | | | 163 | 5000 | | |
| | | | | 164 | 6000 | | |
| 165 | 10000 | | | | | | |
| 166 | 15000 | | | | | | |
| 167 | 20000 | | | | | | |
| 168 | 25000 | | | | | | |
| 169-172 | Idle | | | | | | |
| 173-174 | Hibernate Fixture | | | | | | |
| 175-176 | Hibernate Off | | | | | | |
| 177-178 | Sun Protection Position | | | | | | |
| 179-180 | Sun Protection Off | | | | | | |
| 181-185 | PanTilt Smooth (default) | | | | | | |
| 186-190 | PanTilt Fast | | | | | | |
| 191-195 | CMY Speed Normal | | | | | | |
| 196-200 | CMY Speed Fast (default) | | | | | | |
| 201-210 | Dimmer Curve Linear (default) | | | | | | |
| 211-220 | Dimmer Curve Square | | | | | | |
| 221-230 | Dimmer Curve Inverse Square | | | | | | |
| 231-240 | Dimmer Curve S-Curve | | | | | | |

DMX TRAITS: CHANNEL FUNCTIONS & VALUES

Features subject to change without notice

| MODE/CHANNEL | | | | VALUE | FUNCTION | FADE STATUS | DEFAULT VALUE |
|--------------|----------|------------------|------------------|---------|----------------------------------|-------------|---------------|
| STANDARD | EXTENDED | FRAMING STANDARD | FRAMING EXTENDED | | | | |
| 25 | 36 | 34 | 56 | 241 | Internal program 1 (Scene 1-8) | Snap | Snap |
| | | | | 242 | Internal program 2 (Scene 9-16) | | |
| | | | | 243 | Internal program 3 (Scene 17-24) | | |
| | | | | 244 | Internal program 4 (Scene 25-32) | | |
| | | | | 245 | Internal program 5 (Scene 33-40) | | |
| | | | | 246 | Internal program 6 (Scene 41-48) | | |
| | | | | 247 | Internal program 7 (Scene 49-56) | | |
| | | | | 248-249 | Idle | | |
| | | | | 250-251 | Display off | | |
| | | | | 252-253 | Display on | | |
| | | | | 254-255 | Idle | | |

REMOTE DEVICE MANAGEMENT (RDM)

NOTE: In order for RDM to work properly, RDM enabled equipment must be used throughout the entire system, including DMX data splitters and wireless systems.

Remote Device Management (RDM) is a protocol that sits on top of the DMX512 data standard for lighting, allowing the DMX systems of the device to be managed, modified, and monitored remotely (hence, remote device management). This protocol is ideal for fixtures installed in locations that are not easily accessible.

With RDM, the DMX512 system becomes bi-directional, allowing a compatible RDM enabled controller to send out a signal to devices on the wire, as well as allowing the fixture to respond (known as a GET command). The controller can then use it's SET command to modify settings that would typically have to be changed or viewed directly via the unit's display screen, including the DMX Address, DMX Channel Mode, and Temperature Sensors.

FIXTURE RDM INFORMATION:

| RDM Code | Device ID | Device Model ID | Personality ID |
|----------|-----------|-----------------|----------------|
| 0X6E4 | OPEN | 1764 | OPEN |

Please be aware that not all RDM devices support all RDM features, and therefore it is important to check beforehand to ensure that the equipment that you are considering includes all of the features that you require.

The following parameters are accessible in RDM on this device:

| LED FIXTURE | |
|-----------------------------|-----|
| Sensor Definition | YES |
| Sensor Value | YES |
| Device Model Description | YES |
| Manufacturer Label | YES |
| Device Label | YES |
| DMX Personality | YES |
| DMX Personality Description | YES |
| Device Hours | YES |
| Pan Invert | YES |
| Tilt Invert | YES |
| Display Invert | YES |

ERROR CODES

When power is applied, the unit will automatically enter a “Reset/Test” mode. This mode brings all the internal motors to a home position. If there is an internal problem with one or more of the motors an error code will flash in the display in the form of “XXer” where as XX will represent a function number. For example, when the display shows “0Er” it means there is some type of error with the Pan motor. If there are multiple errors during the start-up process they will all flash in the display. For example: if the fixtures has errors on **Channel 1, 2, and 5** all at the same time, you will see the error message “01Er”, “02Er”, and “05Er” flash repeated 5 times.

If an error does occur during the initial start-up procedure the fixture will self-generate a second reset signal and try to realign all the motors and correct the errors. If the error persists after a second attempt a third attempt will be made. If after a third attempt all the errors have not been corrected the fixture will make the following determinations:

- **3 or More Errors:** The fixture cannot function properly with three or more errors therefore the fixture will place itself in a stand-by mode until subsequent repairs can be made.
- **Less Than 3 Errors:** The fixture has less than 3 errors; therefore, most other functions will work properly. The fixture will attempt to operate normally until the errors can be correct by a technician. The errors in question will remain flashing in the display as a reminder of internal errors.

| Error Codes subject to change without notice | |
|--|---|
| ERROR CODES | DESCRIPTION |
| PAN Er TILT Er | Movement is not located in the default position after the reset. This message will appear after a fixture reset if the magnetic-indexing circuit malfunctions (sensor failed, or magnet is missing) or there is a motor failure (defective motor or a defective motor IC drive on the main PCB). This error may also be displayed if the head/yoke was blocked during TILT Er a reset function. |
| Cyan Color Er Magenta Color Er Yellow Color Er CTO Color Er Color Wheel Er Focus Er Zoom Er Iris Er Animation Er Animation Rot Er | Movement is not located in the default position after the reset. This message will appear after a fixture reset if the magnetic-indexing circuit malfunctions (sensor failed, or magnet is missing) or there is a motor failure (defective motor or a defective motor IC drive on the main PCB). |

ELATION ETHERNET UPDATER

You can obtain the **Elation Ethernet Updater** by contacting Elation Service:

ELATION SERVICE USA - Monday - Friday 8:00am to 4:30pm PST 323-582-3322 | Fax 323-832-9142 | support@elationlighting.com

**ELATION SERVICE EUROPE - Monday - Friday 08:30 to 17:00 CET
+31 45 546 85 63 | Fax +31 45 546 85 96 | support@elationlighting.eu**

The **Elation Ethernet Updater** is an EXE file, which only works on a PC System. Once you've received the Elation Ethernet Updater RAR file from Elation Service via email, download and extract the EXE file. With the file extracted, click **Elation Ethernet Updater setupV100.exe** to launch the installation wizard.



Follow the prompts once the Elation Ethernet Updater EXE has launched the Setup Wizard.

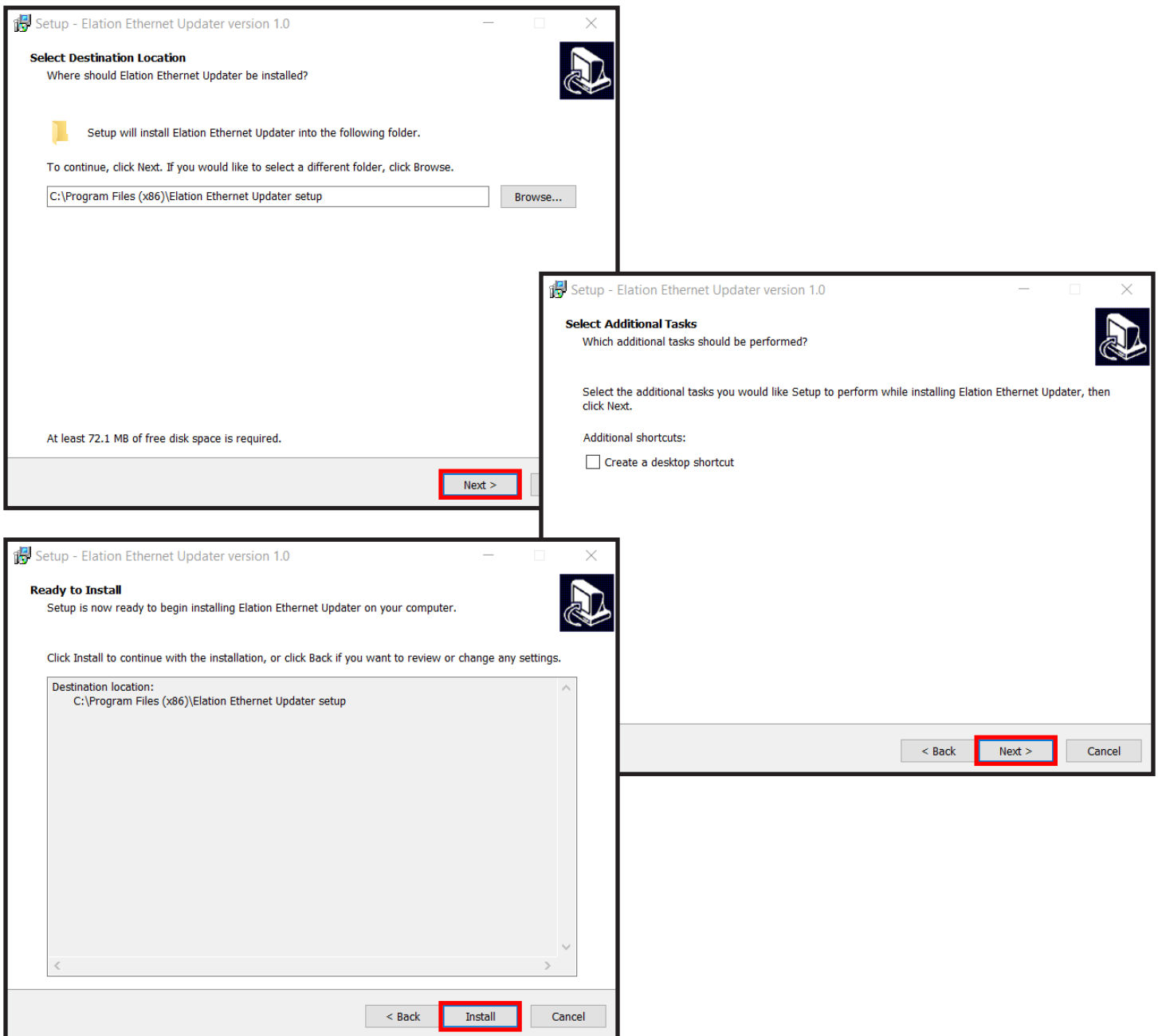

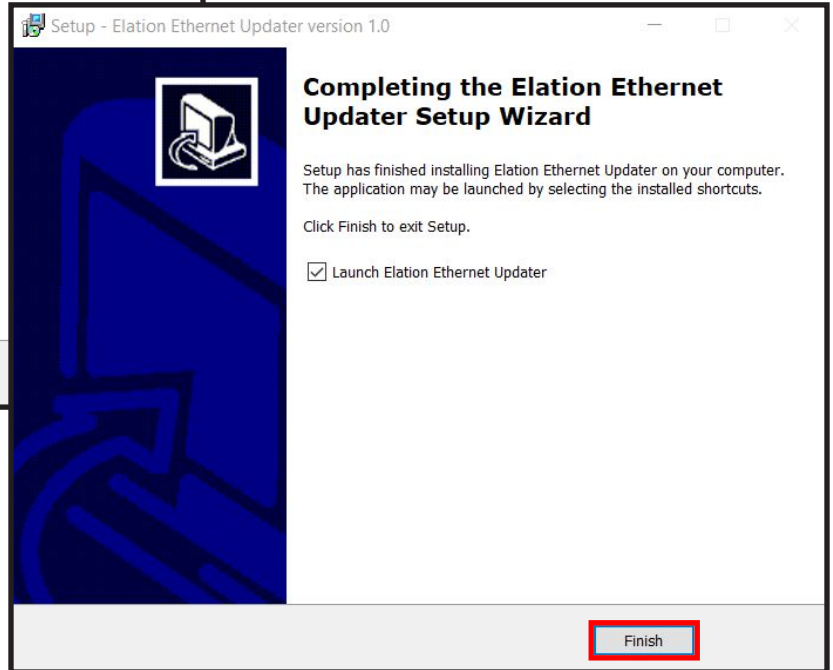
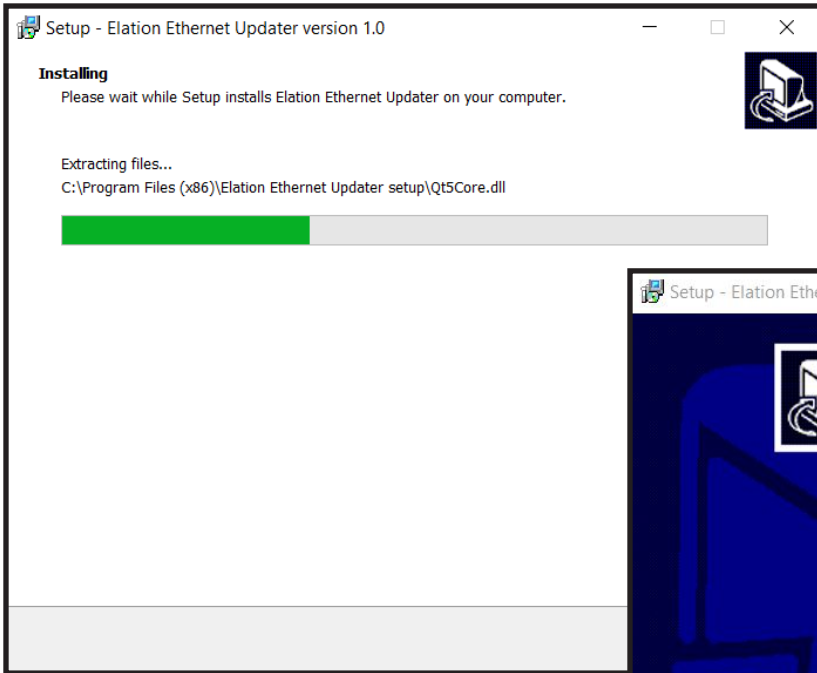

Once you have installed Elation Ethernet Updater, it will launch automatically (unless you unchecked the “Launch Elation Ethernet Updater”), or you can open it anytime by clicking on the icon.



Once opened, it will automatically identify your local IP. Click “Scan fixture” and create a connection. The fixture identity will appear in the Update List on the left side of browser. A connection will fail to establish if the fixture IP and Local IP are not in the same network segment.

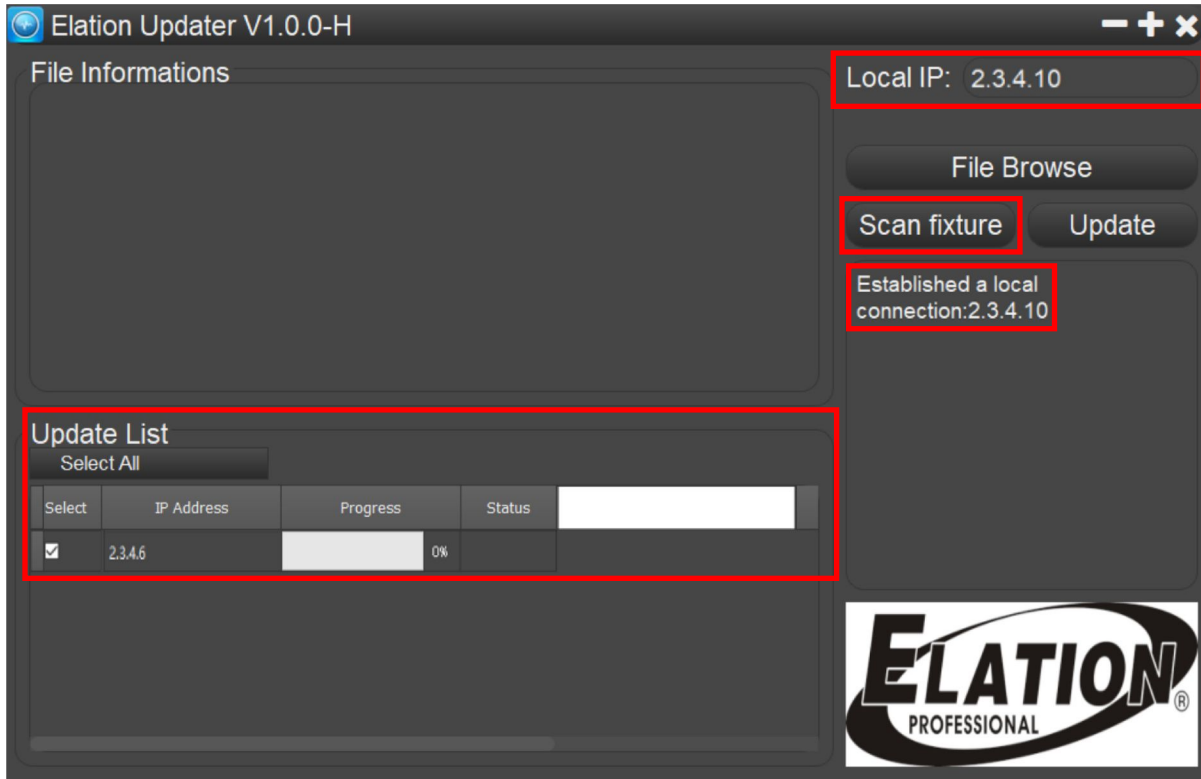

Click “File Browse” to select the files you want to download. The download Progress is displayed in the File information chart as a percentage bar graph.

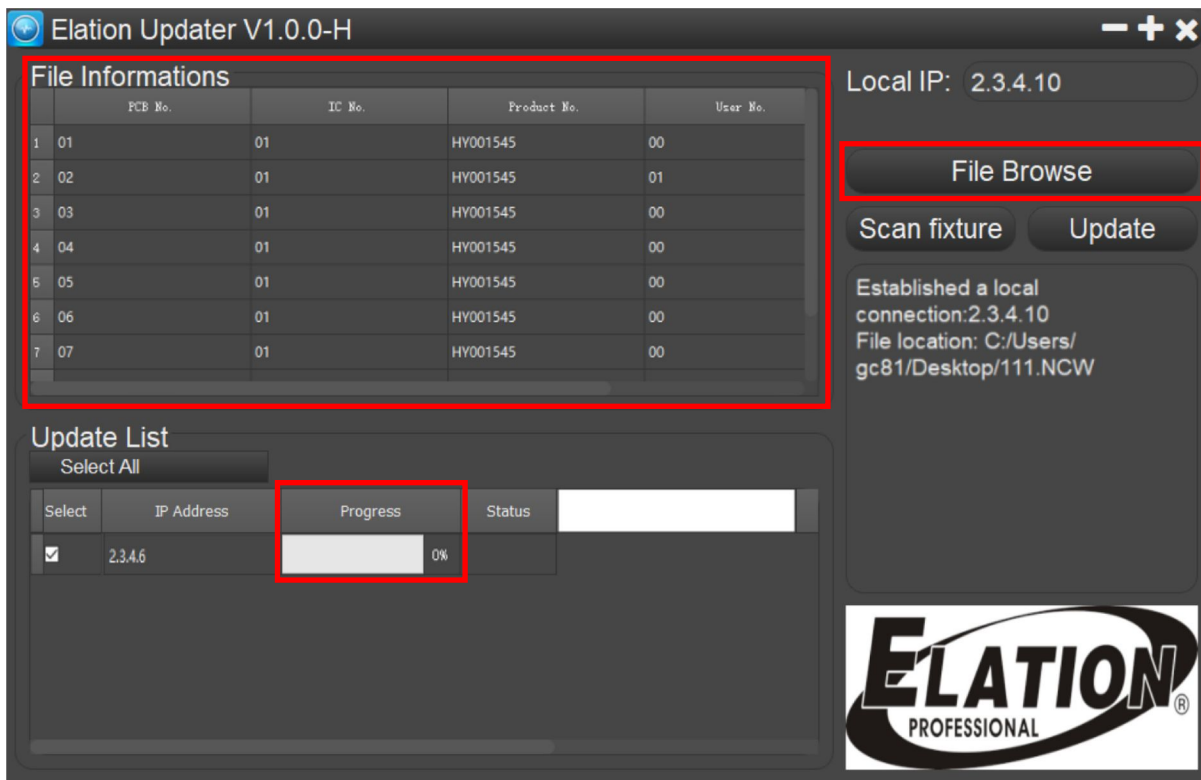

Click Update, then wait for the download Progress to reach 100% before closing Updater. The Elation Ethernet Updater can update up to 31 fixtures via connection to a PC.

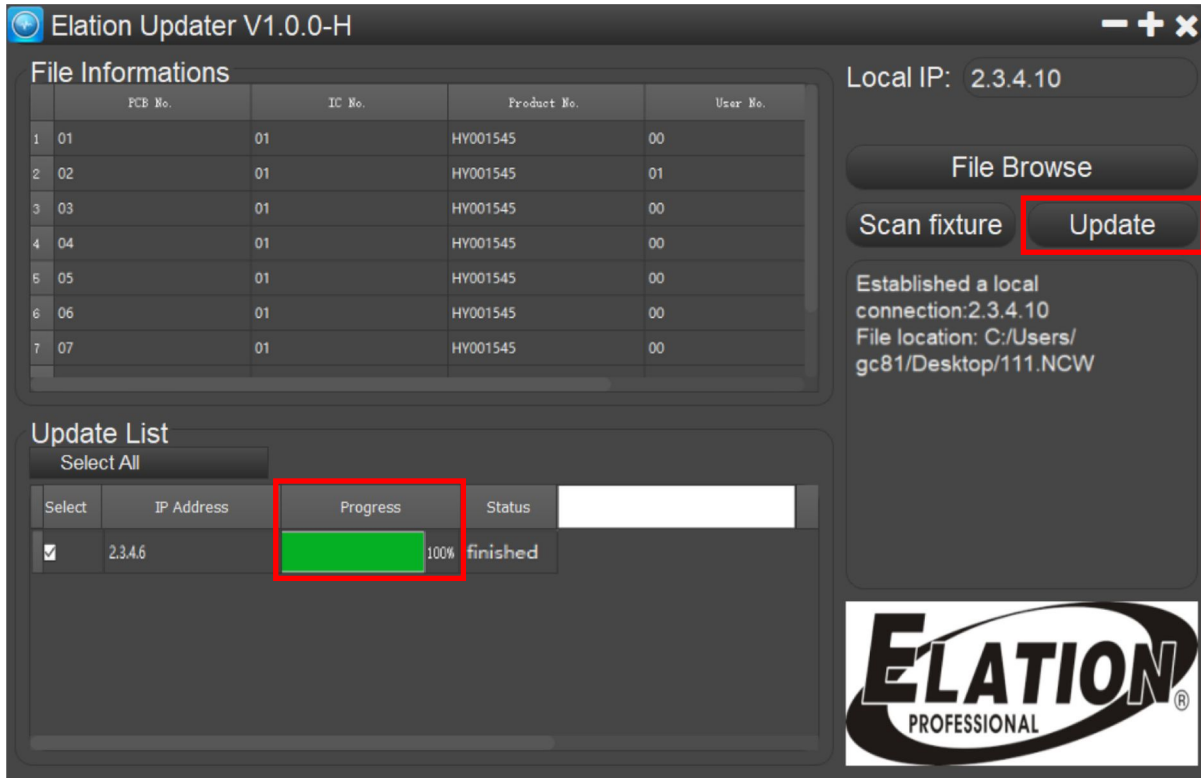

SPECIFICATIONS

SOURCE

1200W 6,500K Bright White LED Engine
30,000 Hour Average LED Life*

*May vary depending on several factors including but not limited to:
Environmental Conditions, Power/Voltage, Usage Patterns (On-Off Cycling), Control, and Dimming.

PHOTOMETRIC DATA

70,000 Total Lumen Output
CRI 70+ (82+ with HCRI Filter)
2:1 Peak Field
Zoom Range 5° - 50°
Beam Angle 4.4° - 28.1°
Field Angle 7.2° - 44°

EFFECTS

Motorized Zoom (220mm / 8.7 in Front Aperture)
Full 360° Bi-Directional Animation Wheel
Variable Frost Filter
Motorized Iris with Variable Pulse Effects
Variable 16-bit Dimming Curve Modes
High Speed Electronic Shutter and Strobe
DMX Controllable LED Refresh Rate
Pan Angle: 540°/630°
Tilt Angle: 266°

COLOR

CMY Color Mixing
Linear CTO Color Correction
6 Dichroic Colors including High CRI Filter and UV

GOBOS

5 Rotating / Indexing Interchangeable Beam Shaping + FX Gobos

OPTIONAL FRAMING MODULE

4 Rotating Full Blackout Framing Blades
+/-45° Framing Indexing

CONTROL / CONNECTIONS

4 DMX Channel Modes (25/ 36 / 34 / 56)
16-bit Pan, Tilt and Dimming Control
Motorized Focus
DMX, RDM, Art-NET, sACN Protocol Support
(6) Button Touch Control Panel
Full Color 180° Reversible LCD Menu Display
Hibernation Mode (Power Save)
5pin XLR DMX In/Out
IP65 RJ45 ethernet In/Out
IP65 Locking Power Cable In
With Wired Digital Communication Network

SIZE / WEIGHT

Length: 18.0 in (458mm)
Width: 24.9 in (633mm)
Height: 33.9 in (860mm)
Weight: 105 lbs. (47.6kg)

ELECTRICAL

AC 200-240V 50/60Hz
Max Power Consumption 1,700W
14°F to 113°F (-10°C to 45°C)

APPROVALS / RATINGS

CE | cETLus | IP65



Specifications and documentation subject to change without notice.

DIMENSIONS

*Drawings not to scale. Specifications and improvements in the design of this unit and this manual are subject to change without notice.

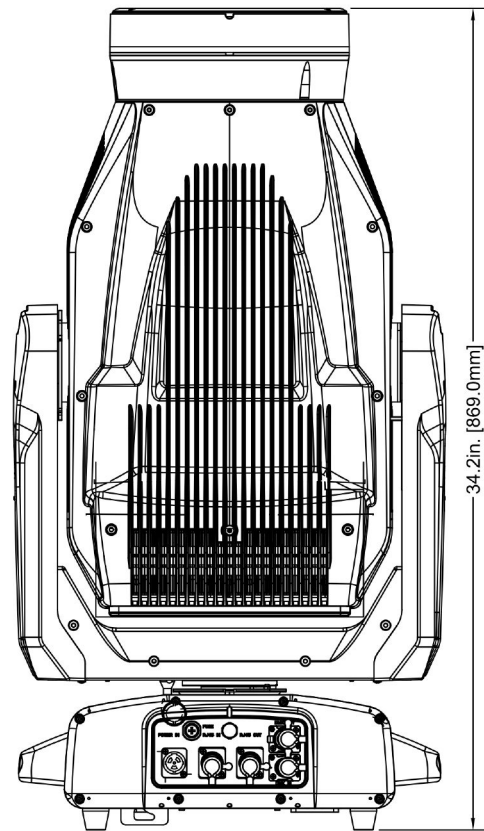
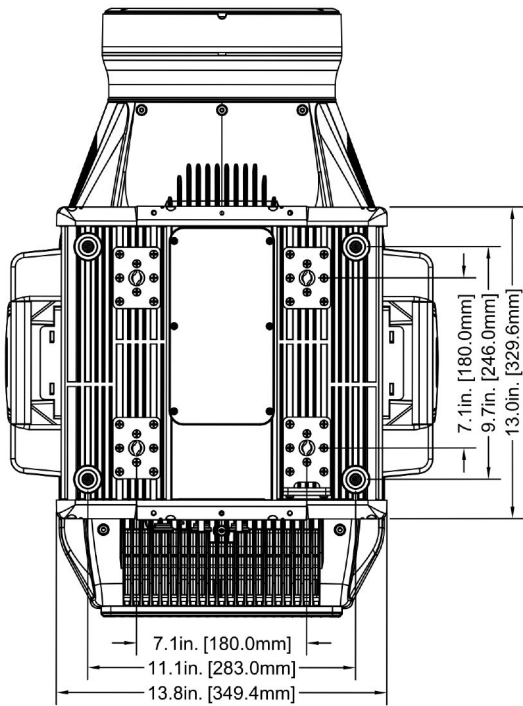
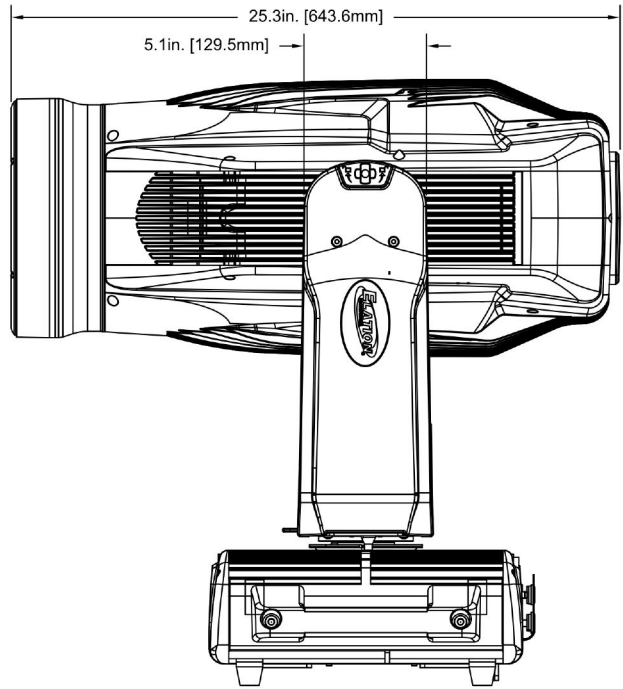
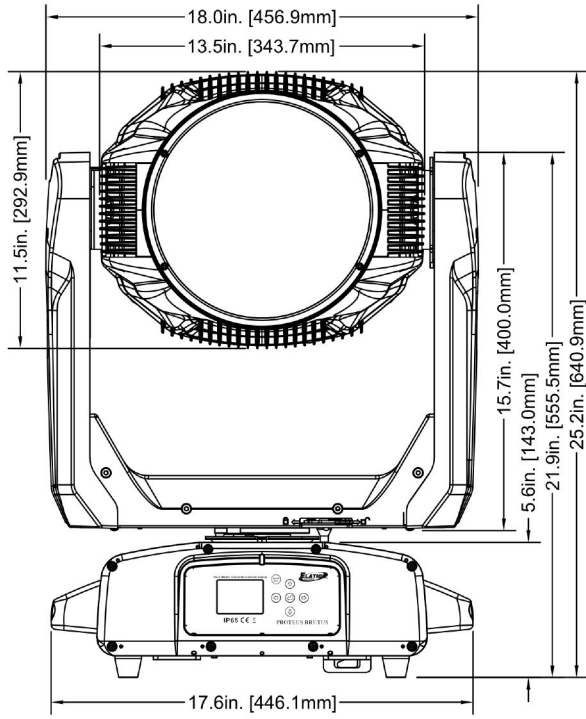

DIMENSIONS

*Drawings not to scale. Specifications and improvements in the design of this unit and this manual are subject to change without notice.

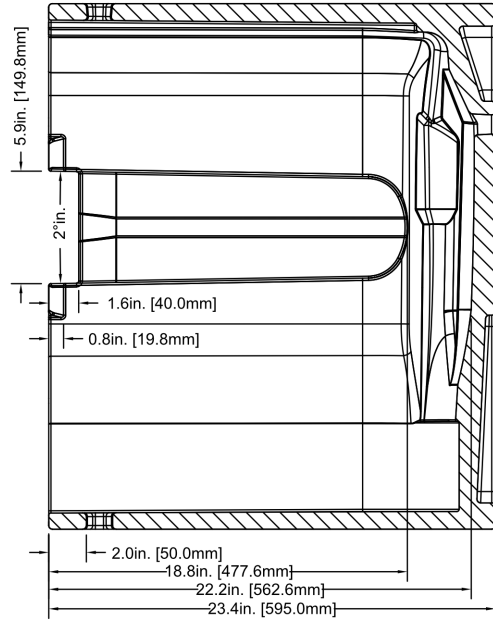
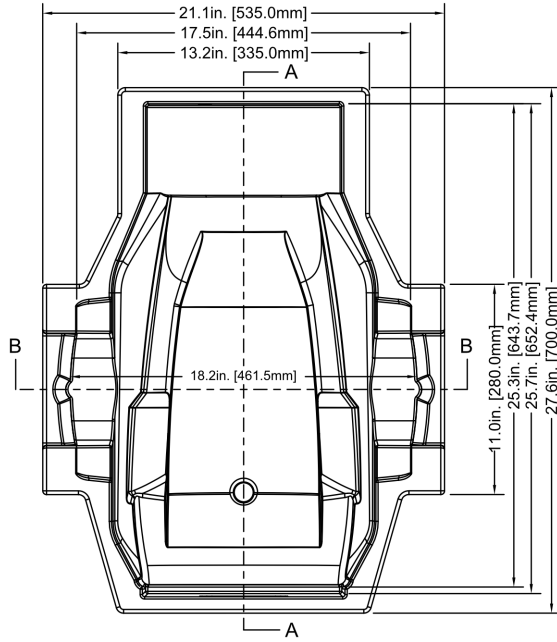

A - A

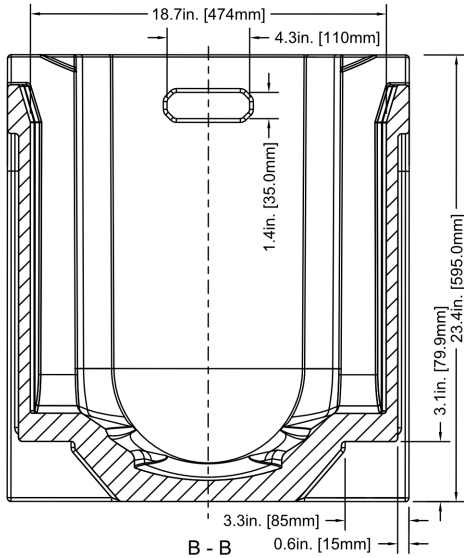

B - B

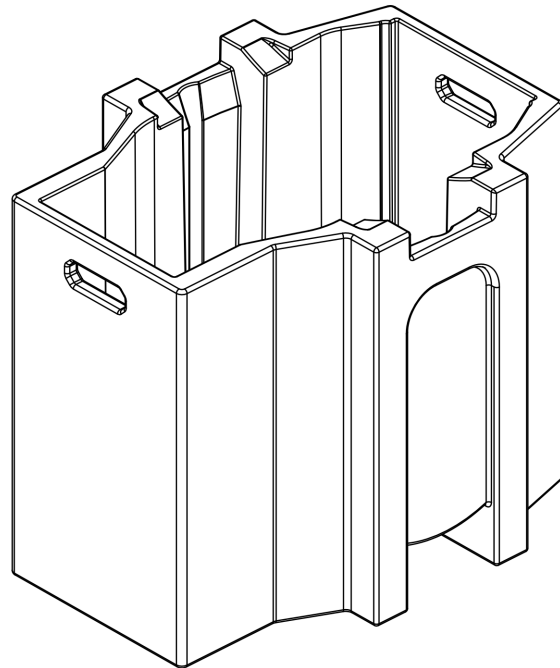
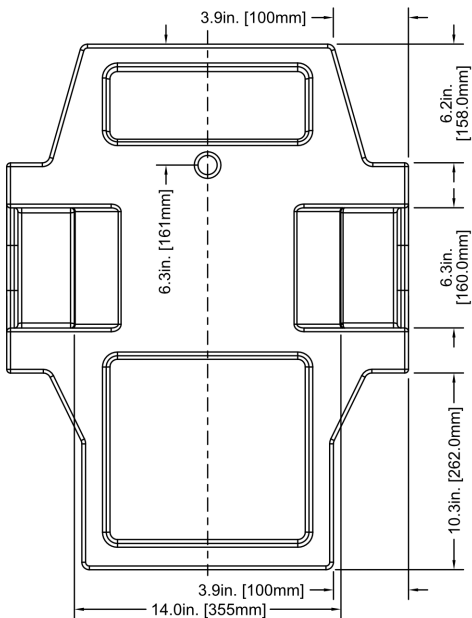

OPTIONAL ACCESSORIES

| ORDER CODE | ITEM |
|---------------|---|
| TRIGGER CLAMP | Heavy Duty Wrap Around Hook Style Clamp |
| SIP126 | 5 ft. (1.5m) IP65 Twist Lock Power Link Cable |
| AC5PDMX5PRO | 5 ft. (1.5m) 5pin PRO DMX Cable |
| | Additional Cable Lengths Available |

FCC STATEMENT

This device complies with Part 15 of the FCC Rules. Operation is subject to the following two conditions: (1) this device may not cause harmful interference, and (2) this device must accept any interference received, including interference that may cause undesired operation.

FCC RADIO FREQUENCY INTERFERENCE WARNINGS & INSTRUCTIONS

This product has been tested and found to comply with the limits as per Part 15 of the FCC Rules. These limits are designed to provide reasonable protection against harmful interference in a residential installation. This device uses and can radiate radio frequency energy and, if not installed and used in accordance with the included instructions, may cause harmful interference to radio communications. However, there is no guarantee that interference will not occur in a particular installation. If this device does cause harmful interference to radio or television reception, which can be determined by turning the device off and on, the user is encouraged to try to correct the interference by one or more of the following methods:

- Reorient or relocate the device.
- Increase the separation between the device and the receiver.
- Connect the device to an electrical outlet on a circuit different from which the radio receiver is connected.
- Consult the dealer or an experienced radio/TV technician for help.

Energy Saving Matters (EuP 2009/125/EC)

Saving electric energy is a key to help protecting the environment. Please turn off all electrical products when they are not in use. To avoid power consumption in idle mode, disconnect all electrical equipment from power when not in use. Thank you!



