

Battle Fogger

Operator's Manual

Table of Contents

Introduction	3
Microprocessor Control	3
Water Base Fog Technology	3
Warning	3
Important Safety Instructions:	3
Safety Precautions	3
Technical Specifications	4
Technical Drawings	4
Operating Procedure	5
Remote Handset Operation	5
Remote Handset LED Indicator.....	5
Remote and External Control Features	6
Maintenance	6
Exterior:.....	6
Heat Exchanger:	6
Recommended Fluids	6
Warranty	7
Contact Information	7

Note: Please read entire manual before operating the Battle Fogger

Introduction

The Battle Fogger is a Microprocessor Controlled, Water Based Fog Generating System.

Microprocessor Control

The Battle Fogger features microprocessor control. From temperature regulation to taper back flow control, all of the functions are monitored and processed by the on-board processor.

Water Base Fog Technology

Water Base Fog Technology is achieved by pumping a glycol/water mixture through a heat exchanger. This will vaporize the fluid as it passes through the processing block. The vaporization of the fluid forces the hot mixture through the output nozzle. When mixed with ambient air, it forms an opaque aerosol (fog). The fog is made up of tiny droplets that form around small particles in the air. The suspended droplets refract the light, allowing the fog to take on the color of the light illuminating it.



Warning

Important Safety Instructions:

1. Do not touch, place hands or expose skin within 20" (50 cm) of the discharge nozzle.
2. Do not remove the outer case.
3. Persons suffering from asthma or allergenic sensitivity may experience irritation, discomfort or allergic symptoms when exposed to fog effects.
4. Ensure that this unit is grounded at all times. Failure to do so may result in serious injury.
5. Use Ultratec Special Effects fluid **ONLY**.

Safety Precautions

1. Ensure that any operation of the machine is supervised by suitably trained and authorized personnel.
2. Do not modify the machine or use a machine which has been damaged in any way.
3. Allow sufficient air circulation around the machine at all times.
4. Protect the machine from direct weather effects and wet locations.
5. Only use fluids manufactured by Ultratec Special Effects.
6. Do not continue to produce fog when visibility is reduced to 20" (50cm) or below.
7. Avoid directing fog output continuously at people, structures or objects within close proximity of the discharge nozzle.
8. Ensure that adequate exhausting arrangements are available in the event of an emergency.
9. Do not place hands or exposed skin within the first 20" (50 cm) of the discharge nozzle at any time during fog production.
10. Fog effects can trigger smoke alarms and detectors. Please take suitable precautions to prevent false alarms.

Technical Specifications

Model:	Battle Fogger
Part Number:	CLF 4200 Battle Fogger 110 v CLF 4205 Battle Fogger 220-240 v
Length:	22.5in 57.1cm
Width:	9.375in 23.8cm
Height:	9.5in 24cm
Net Weight:	25lbs 11.3kg
Power Rating:	120 Volt A.C. 50/60 Hz. 12 Amps. 240 Volt A.C. 50/60 Hz. 6 Amps.
Fluid:	Ultratec Water Base Fog Fluid
Includes:	Full Timer Remote RCT Replacement Kit

Technical Drawings

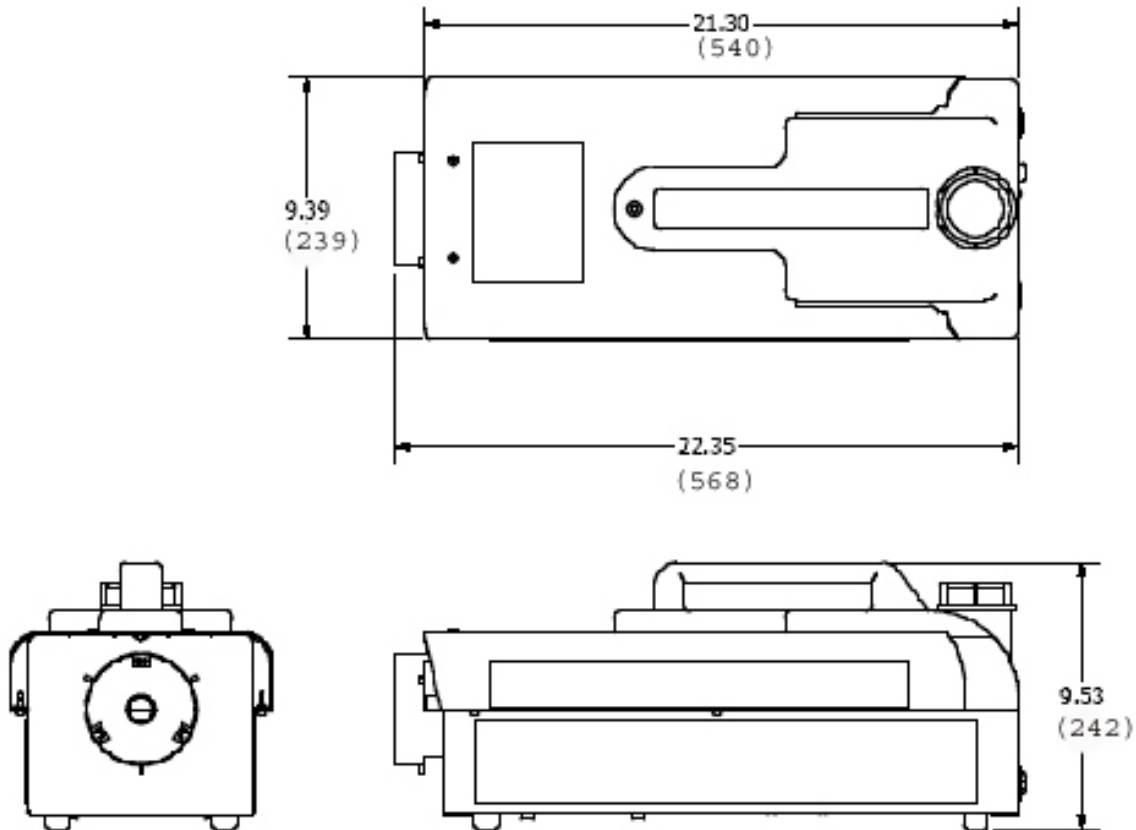

Operating Procedure

1. The Battle Fogger must only be connected to a grounded receptacle capable of sustaining at least 12 Amps 120v or 6 Amps 220-240v. The supply should be 'clean' and free of interference.
2. Open a container of Ultratec Special Effects fog fluid, remove cap and break foil seal (if provided). Remove cap from Battle Fogger fluid reservoir. Fill with fluid, being careful not to overfill reservoir. Replace both caps securely.
3. Connect the remote handset supplied with the machine, to the connector which is located on the rear panel.
4. Turn on the Main Power switch located on the rear panel. The Power switch will illuminate to indicate the presence of power, the handset indicator on the remote handset will also illuminate with a slow flash. If the handset indicator of the remote handset does not illuminate, ensure the connector is properly inserted.
5. The handset indicator will flash slowly as the machine heats up. The indicator will begin flashing quickly when the fog machine is ready to operate. After approximately 9 minutes the indicator light will be solid when the fog machine has fully heated up for full optimum fog output.
6. It may now be necessary to prime fluid into the system to expel any air that might be present. The Variflow control on the remote handset should be set to Full position and Handset Indicator is solid (full heat). A dry hose can take between 45 - 60 seconds to prime. This is normal because of the inside diameter of the hose. This only needs to be done if the unit was left to run dry.

Industrial Option Only:

To adjust the depth of the hose, simply loosen the nut and slide it up or down the hose and retighten. Be careful not to pinch off the flow of fluid.

Remote Handset Operation

The fog output time is set using the 'Duration' control (0 to Max / 1-180 sec) and the time between successive fog outputs is set using the 'Interval control (0 to Max / 0-240 sec). Continual flow can be achieved if 'Interval' setting is at 0.

Remote Handset LED Indicator

The Battle Fogger Remote Handset was designed to indicate the following operation modes.

Slow Flashing Light: Indicates unit is not ready to operate but still in heating mode, fog is not available at this point.

Quick Flashing Light: Indicates unit is ready to operate but still in heating mode, some fog is available at this point.

Solid Light: Indicates that the unit is ready to fog at full output.

No Light: Indicates problem; a loss of power or remote is not connected. If these fail to correct the problem, contact your local Ultratec Special Effects dealer.

3 Flashes & Pause: Over temp error / shut down



Remote and External Control Features

External Remote Connector

The standard Remote Handset cable may be extended from the machine, and operated effectively away from the Battle Fogger. The maximum recommended cable length is 200 Feet.

Maintenance

Exterior:

The casing of the Battle Fogger is steel with a powder paint coating. To clean, simply wash with mild soap and warm water.

Heat Exchanger:

The use of high quality Ultratec Special Effects fluid should result in a long heat exchanger life. (See warranty policy later in this manual.)

Note: Cleaning/Rapid Change procedure can found on the Battle Fogger product page on www.ultratecfx.com

Recommended Fluids

Director's Choice Fog Fluid: The choice of professionals. Director's Choice creates a cloud of fog with a medium hang time while remaining clean, white, dry, and odorless.

Pro Beam Long Lasting Fog Fluid: With a hang time 2-3x greater than the Director's Choice Fog Fluid, the Pro Beam solution produces a slightly less white fog while remaining clean, dry, and odorless.

Quick Dissipating Fog Fluid: This fast dissipating fluid is great for applications or effects that require quick dissipation of fog. It produces excellent steam effects that resemble nitrogen bursts and it also keeps low-lying fog from rising too quickly when it is used with the LSG or LSX.

Extra Quick Dissipating Fog Fluid: Dissipates 2x the rate of Quick Dissipating Fog Fluid while maintaining similar characteristics.

Molecular Fog Fluid: A faster dissipation versus the Director's Choice Fog Fluid. This thick, clean, white fog is an optimal solution for a dense low-lying fog effect when chilled with the LSG or LSX machines.

Maxi Fog Fluid: The perfect balance between price and performance. Maxi Fog is the ideal solution for those who require high volume without compromise.

EZ Kleen Preventative Maintenance Fluid: Using EZ Kleen preventative maintenance fluid on a regular basis ensures longer life for the heat exchanger in Ultratec fog machines by reducing blockage

Heavy Smoke Fluid: Our original fluid is used for many applications where a cloud of smoke is required with a medium hang time. Clean, white, dry and odorless smoke has made this the "professional's choice".

Quick Dissipating Smoke Fluid: This blend was created for training use in the fire fighting industry and is now extensively used for many other applications. This fluid will prevent low lying smoke from rising too quickly.

Logger Lasting Smoke Fluid: This formulation produces a clean, dry, odorless, slightly less white smoke that "hangs" in the air 2-3 times longer than our class smoke fluid.

NOTE: All of our fog fluids are water based. Damage will occur if Haze Fluid is used in the Battle Fogger.

Warranty

Warranty:	Hardware products come with a one year warranty on parts and labor. Unless stated otherwise, this will refer to manufacturer defects only. All warranty is based on destination of the original sale. Any additional costs incurred are the responsibility of the Dealer and/ or the customer. Abuse or poor maintenance is not accepted. Proof of purchase or proof of sale must always accompany all warranty returns. An RA (Return Authorization) number must be noted on the outside of each box being returned to our facility. Any package(s) without an RA number clearly marked, will not be accepted by our receiving department. Freight on warranty items are freight prepaid to our facility and we will prepay freight back to your facility following repair. This will be done by the most economical means available. Should you require the item express-returned, the dealer is responsible for request indication and any difference in freight cost. Export Distributors are required to carry out the warranty repair, parts will be supplied by Ultratec.
Return Policy:	Return of any product must be done within 30 days of purchase. The package must be returned freight prepaid and the RA number clearly marked on the outside of the box.
Warning:	Ultratec Special Effects considers all of it's product to be safe for use in the application it was intended. Ultratec Special Effects takes no responsibility for misuse or incorrect use. Always refer to the Product Manual for proper use.

Contact Information

Head Office

Ultratec Special Effects
1960 Blue Heron Drive
London, Ontario N6H 5L9

Direct: 519-659-7972
Toll Free: 866-534-5557
Fax: 519-659-7713

Europe Office

Ultratec Special Effects GmbH
Dieselstrasse 30-40
60314
Frankfurt am Main
Germany

Direct: 49-69-87-000-1850
Fax: 49-69-87-000-1899

Canadian Shipping Address

(For All Canadian Repairs)
Ultratec Special Effects
1960 Blue Heron Drive
London, Ontario N6H 5L9

USA Shipping Address

(For All USA Repairs)
Ultratec Special Effects
640 Gadson Street
Groveland, Florida 34736

Please remember to include the **RA Number on all items being shipped for repairs.**

To retrieve an RA Number visit www.ultratecfx.com and click on the "Service" section. Then click on "Return Authorization Request" which is located on the left hand side of the page.

If you have any questions or require assistance please contact service at 519-951-3357/866-534-5557 or by email at Service@Ultratecfx.com.